



**Schloss-  
& Beschlag-  
konzepte**

für den Yachtbau

**Lock  
& Hardware  
Concepts**

for yachtbuilding



**SCHWEPPER**

[www.schwepper.com](http://www.schwepper.com)

## Yachtkatalog

**Ausgabe**  
2010

### **Yachtkatalog**

Produktkatalog für den Schiffbau zu bestellen unter: [info@schwepper.com](mailto:info@schwepper.com)

### **Vorbehalt**

Der Inhalt dieses Kataloges unterliegt jederzeit technischen Änderungen. Der aktuellste Stand ist im Internet unter [www.schwepper.com](http://www.schwepper.com) zu finden.

### **Schlösser und Beschläge**

für den Schiffbau / Massentransport-systeme / Sonderschlossbau

## Yacht Catalog

**Edition**  
2010

### **Yacht Catalog**

Product catalogue for Shipbuilding to be ordered at: [info@schwepper.com](mailto:info@schwepper.com)

### **Reminder**

The content of this catalogue underlies constant technical changes. The most actual edition is found in the internet under [www.schwepper.com](http://www.schwepper.com).

### **Locks and hardware**

for shipbuilding / masstransportation systems / customized locks and hardware



# SCHWEPPER

**Lock & Hardware Concepts  
for Ship & Yachtbuilders**

Postfach / PB 10 06 61  
42571 Heiligenhaus / Germany

Velberter Str. 83  
42579 Heiligenhaus / Germany

Telefon / Phone +49 2056 - 5855-0  
Fax VK / Sales +49 2056 - 5855-41

<http://www.schwepper.com>  
email: [schwepper@schwepper.com](mailto:schwepper@schwepper.com)

---

# Welcome to the World of **Schwe**

Schwepper GmbH, gegründet im Jahre 1872, genießt weltweiten Ruf für hohe Qualität. Als Hersteller und Ansprechpartner für Yacht-Besitzer und -Bauer sowie für Planer und Berater, ist es unser Ziel, dem Yachtbau einen entscheidenden Beitrag zur Erhaltung von Tradition und kundenorientierter Wertarbeit zu leisten. Mit Stolz stellen wir Ihnen hier eine kleine aber feine Auswahl unserer hervorragenden Produkte für den Yachtbereich vor. Schwepper ist auch als Lieferant von ausgezeichneten Produkten für die Marine und den kommerziellen Schiffbau bekannt.

Schwepper of Germany, founded 1872, enjoys world wide reputation for excellent quality. Serving yacht owners as well as yacht builders, architects and consultants, our main objective is to offer a decisive contribution to the maintenance of tradition and customised workmanship to the yacht industry. We are proud to present here a small but fine selection of our outstanding yacht products. Schwepper is also renowned for its products to the naval industry and to commercial ship builders.

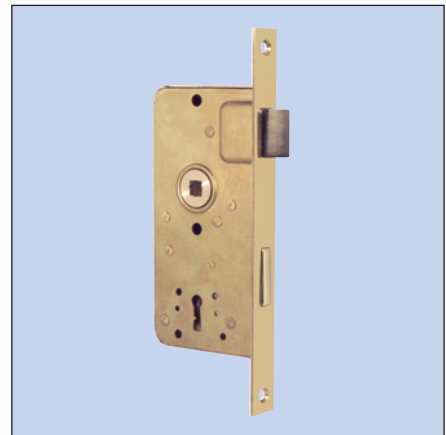

Das Verständnis für individuelle Ansprüche, kombiniert mit dem Bestreben nach höchster Kundenzufriedenheit, spiegelt sich in der Produktauswahl von Schwepper wieder. Hochwertige und haltbare Oberflächen unserer Schlösser und Beschläge sind Komplimente für jede Yacht und ihren Besitzer.

Understanding of individual needs combined with the persuasion of total customer satisfaction is truly reflected in Schwepper's product policy. Our choice of fine and durable finishes is a compliment to any yacht as well as to her owner.

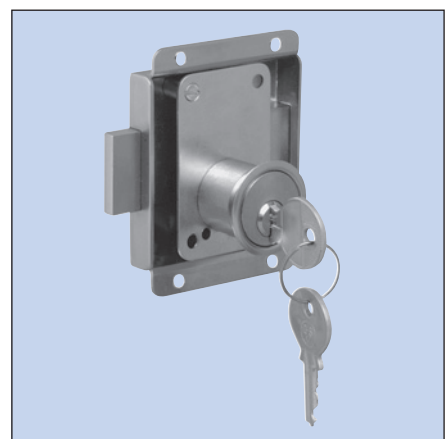

# pper

Ob in reinem Messing, poliert oder verchromt, oder in rostfreiem Stahl - wir liefern eine ausgereifte Produktpalette zu einem attraktiven Preis-/Leistungsverhältnis.

Whether pure brass, polished or chromium plated, or stainless steel, we offer a wide range of affordable hardware to meet Your requirements.

## Schlösser und Beschläge Locks and hardware



Bei Schwepper wird jeder Artikel für den anspruchsvollen Gebrauch hergestellt.

At Schwepper every single unit is made to ensure long lasting usage.

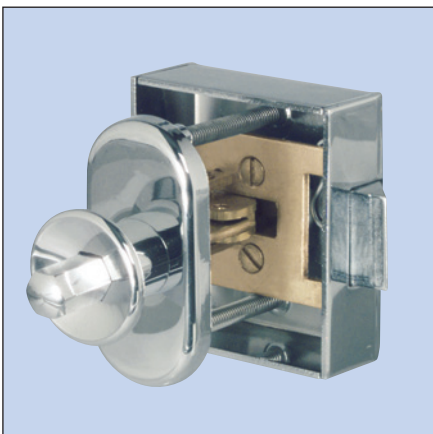
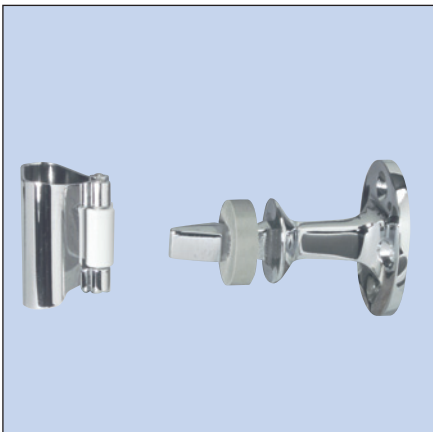

Die Realisierung einzigartiger und vollständiger Produktfamilien ist Ihre Garantie für technische Lösungen in höchster Qualität. Ob für den Innen- oder Außenbereich, Funktionalität und Widerstandsfähigkeit gegen auf See herrschende Luft- und Wetterbedingungen ist eine Herausforderung, der unsere Schlösser und Beschläge für den Yachtbau immer mit großem Erfolg gewachsen sind.

The provision and supply of a unique and complete product family from Schwepper guarantees You a reliable technical solution of choice quality. Interior or exterior hardware – functionality and the superior nature to withstand rough conditions at sea is a challenge that has been successfully mastered by our products since generations.

## Material und Oberflächen

## materials and finishes



Messing matt verchromt

brass satin chrome plated



Messing poliert verchromt

brass polished chrome plated



Messing poliert

brass polished



Aluminium eloxiert

aluminium anodized



Edelstahl gebürstet

stainless steel brushed



Edelstahl poliert

stainless steel polished

Mpni

Messing poliert vernickelt

brass bright nickel-plated

Estr

Edelstahl rostfrei

stainless steel

PVD-beschichtet auf Anfrage

PVD covered on request

vergoldet auf Anfrage

gold plated on request

**Yachtbeschlage  
fur den Gro-Yachtbau****Yacht hardware  
for the large yachtbuilding****Seite  
page**

Turschlosser, Drucker, Schilder

door locks, handles, plates

Y 01 - Y 25

Mobelschlosser

cabinet locks

Y 26 - Y 32

Scharniere, Spannverschlusse

hinges, fasteners

Y 33 - Y 36

Turklemmen, Haken,  
Mobelbeschlage, Knöpfe,  
Griffe, Riegeldoor spring catches, hooks,  
cabinet hardware, knobs,  
pulls, bolts

Y 37 - Y 45

## Nummernverzeichnis

## index of numbers

Nummer number	Seite page	Nummer number	Seite page	Nummer number	Seite page	Nummer number	Seite page
145	Y-34	2210	Y-9	3361 A	Y-43	4825	Y-42
145 A	Y-34	2406	Y-38	3416	Y-34	5078	Y-37
149	Y-41	2436 FOU	Y-10,11	3417	Y-34	5078 A	Y-37
164	Y-45	2436 ZM	Y-10,11	3461	Y-43	5108	Y-39
168	Y-41	2438 FOU	Y-10,11	3461 A	Y-43	5205	Y-30
180	Y-34	2438 ZM	Y-10,11	3518	Y-30	5205 A	Y-30
182	Y-34	2439 FOU	Y-10,11	3533	Y-28	5432	Y-41
193	Y-34	2439 ZM	Y-10,11	3736	Y-26	5502	Y-25
229 G	Y-45	2494 G	Y-44	3801 F	Y-5	5602	Y-25
232	Y-40	2507 G	Y-45	3801 WC	Y-7	5605	Y-31
233	Y-40	2512	Y-43	3801 Z	Y-5	5620 S	Y-12
236	Y-37	2512 A	Y-43	3801 ZR	Y-5	5626	Y-5,7
236 A	Y-37	2512 B	Y-43	3811 F	Y-5	5626 F	Y-5
238	Y-44	2534	Y-36	3811 WC	Y-7	5651	Y-41
337	Y-25	2537	Y-36	3811 Z	Y-5	5762	Y-25
353	Y-25	2544	Y-36	3853	Y-29	5830	Y-25
383	Y-25	2574	Y-38	3854	Y-29	5845	Y-29
922	Y-15,17	2654	Y-42	3928 F	Y-19	5845 S	Y-29
923	Y-12,14,15,17	2658	Y-42	4026	Y-20,21	5846	Y-29
923 F	Y-12	3038 K	Y-35	4026 F	Y-20,21	5847	Y-29
924	Y-15	3038 KH	Y-35	4040	Y-20	5928	Y-16
925	Y-15	3038 L	Y-35	4040 F	Y-20	5928 F	Y-16
928	Y-15	3148	Y-40	4040 FK	Y-21	5928 Z	Y-17
928 F	Y-15	3149	Y-40	4040 K	Y-21	5968	Y-13
928 FWC	Y-15	3152	Y-40	4040 WC	Y-20	5968 F	Y-13
928 ZK	Y-17	3201 F	Y-1	4040 WCK	Y-21	5968 WC	Y-13
968	Y-12	3201 WC	Y-3	4040 Z	Y-20	5968 Z	Y-14
968 F	Y-12	3201 Z	Y-1	4040 ZK	Y-21	5969	Y-24
968 WC	Y-12	3201 ZR	Y-1	4078	Y-37	5969 F	Y-24
968 Z	Y-14	3211 F	Y-1	4078 A	Y-37	5969 WC	Y-24
968 ZK	Y-14	3211 WC	Y-3	4089	Y-38	5969 Z	Y-24
969	Y-23	3211 Z	Y-1	4090	Y-38	6039	Y-28
969 F	Y-23	3226	Y-1,3	4145	Y-42	6039 Z	Y-28
969 WC	Y-23	3226 F	Y-1	4146	Y-33	6643 WCO	Y-4,8
969 Z	Y-23	3241	Y-1,5	4186	Y-33	6643 WCP	Y-4,8
1069	Y-22	3269	Y-18	4309	Y-27	6643 WCR	Y-4,8
1069 F	Y-22	3269 A	Y-18	4340	Y-31	6643 Z	Y-2,6
1069 WC	Y-22	3269 DK	Y-19	4341	Y-31	6645 WCO	Y-4,8
1069 Z	Y-22	3271	Y-26	4346	Y-33	6645 WCP	Y-4,8
1078	Y-41	3271 Z	Y-27	4348	Y-44	6645 WCR	Y-4,8
1346	Y-38	3272	Y-26	4348 A	Y-44	6645 Z	Y-2,6
1367	Y-36	3273	Y-26	4386	Y-33	6674	Y-39
1928	Y-16	3273 Z	Y-27	4410	Y-9	7740	Y-32
1928 F	Y-16	3275	Y-26	4415	Y-3,7	7741	Y-32
1928 Z	Y-17	3310	Y-9	4529	Y-3,7,20,21,22,23	7808	Y-39
1968	Y-14	3343 WCO	Y-4,8	4546	Y-33	7810	Y-39
1968 FK	Y-13	3343 WCP	Y-4	4581	Y-37	7818	Y-39
1968 K	Y-13	3343 WCR	Y-4,8	4586	Y-33	7820	Y-39
1968 WCK	Y-13	3343 Z	Y-2,6	4730	Y-44		
1968 Z	Y-14	3361	Y-43	4805	Y-39		

## Allgemeines / General remarks

### Wichtige Bestellhinweise!

Verwenden Sie für Ihre Bestellungen immer die 6-stellige Bestellnummer – auch dann, wenn Sie die 4-stellige GSV-Nr. angeben. Diese stellt eine schnelle und korrekte Auftragsbearbeitung sicher. Die 6-stellige Bestellnummer ist bei allen Artikeln im Katalog aufgeführt.

### Important when ordering!

You should always refer to our 6-digit order number – also when you use the 4-digit GSV-number. This secures fast and correct order entry. The 6-digit order number is always shown with each article in the catalogue.

### Nicht-Verträglichkeit unterschiedlicher Werkstoffe.

Bei Montage die zu einer direkten Verbindung unterschiedlicher Werkstoffe; z.B. Messing und Aluminium, führt, kann es zu einer elektrolytischen Reaktion mit Korrosionsbildung kommen. Über geeignete Maßnahmen zur Vermeidung solcher Probleme informiert Sie auf Wunsch unsere Verkaufsabteilung.

### Incompatibility of various metals.

Mounting metal parts, e.g. brass and aluminium, together, may result in corrosion of the parts due to an electrolytic reaction. Please contact our sales department for information how to avoid such problems.

### Anschlagrichtung von Türen

Zur Bestimmung der Bestellangabe wird die Tür immer von der Seite betrachtet, auf der die Rollen der Türbänder sichtbar sind.

Sind die Bänder links angebracht, wird das Schloß mit „links“ bezeichnet. Sind die Bänder rechts angebracht, so heißt die Bezeichnung „rechts“.

### Hand of doors

Hand of door is determined from hinge side of door.

Hinges fitted on left hand of door identify lock as „left hand“. Hinges fitted on right hand of door identify lock as „right hand“.

Bei Einsteckschlössern gilt die Bezeichnung „links“ und „rechts“.

Hand of door for mortise locks is „left hand“ and „right hand“.

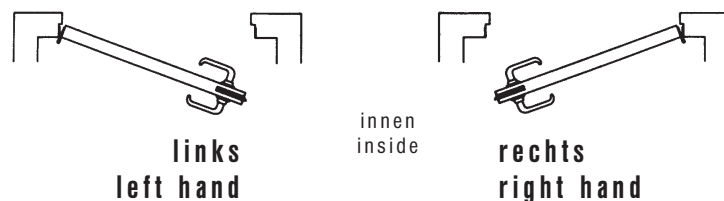

### Bei Kastenschlössern

gilt das gleiche, jedoch ist außer der Bezeichnung „links“ und „rechts“ noch anzugeben, ob die Schlösser für einwärts- oder auswärtsschlagende Türen bestimmt sind.

Hand of door for rim locks is identified in the same manner as for mortise locks except that in addition to „left hand“ and „right hand“ it should be stated whether locks are used for inward or outward opening doors

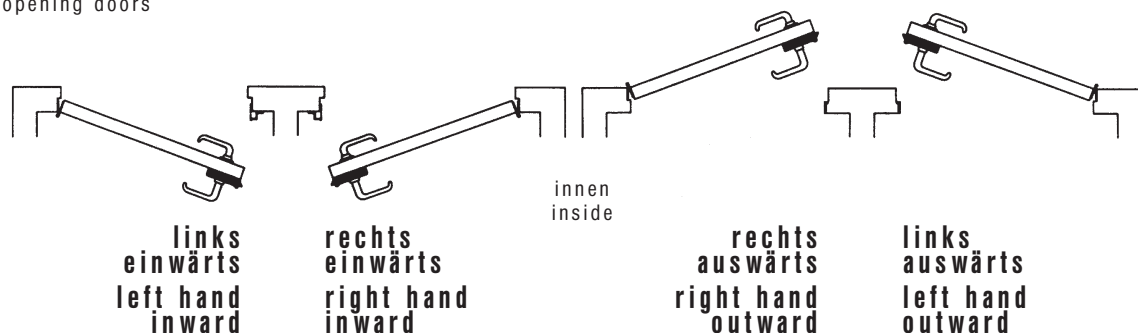



## Schiebetür-Einsteckschlösser

sind für Links- und Rechtstüren gleich.

**Mortise sliding door locks** are non-handed and can be used for left hand and right hand doors.

## Schiebetür-Kastenschlösser

sind für Links- und Rechtstüren verschieden. Bei Bestellung ist immer „links“ bzw. „rechts“ anzugeben.

**Rim sliding door locks** are handed. Hand of door should be stated when ordering.

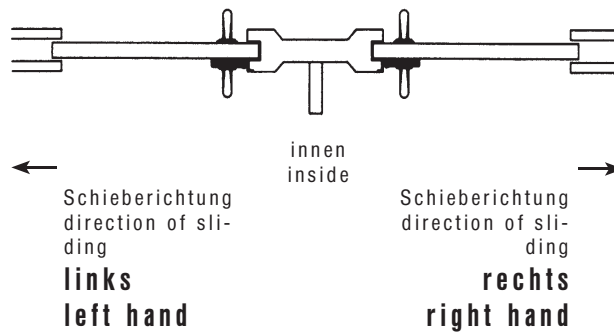

## Besondere Führung der Schloßnuß

zur besseren Stabilisierung und Verlängerung der Haltbarkeit

Serie 32xx

Serie 38xx

Serie 4040

## special bearing of the follower

for better stabilization and prolongation of durability

Serie 32xx

Serie 38xx

Serie 4040

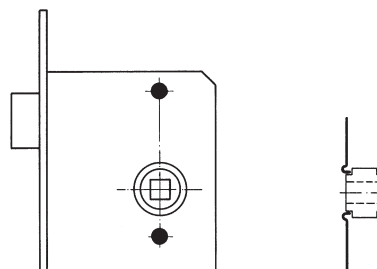

## Stulpschrägen

Einsteck-Türschlösser können mit schrägem Stulp geliefert werden

Serie 32xx

Serie 38xx

## Bevelled fronts

mortise door locks can be supplied with bevelled front

Serie 32xx

Serie 38xx

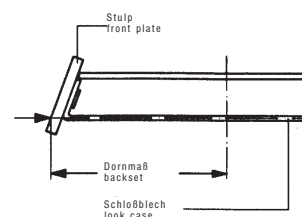
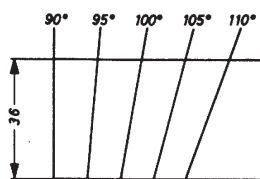

## Sperrhakenloch

für Sperrhaken 3573 G auf Wunsch

## Hole for ajar hook

for ajar hook 3573 G on request



## Kurzschilder

mit Kunststoff-Drückerführung und Distanzstücken für Befestigung mit durchgehenden Hülsenschrauben M5

## short plates

with plastic handle-bearing and distance pieces for fixing with through-bolts M5

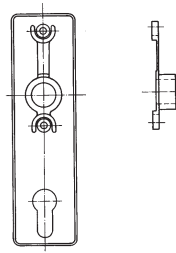

## Hülsenschrauben

6640 K 107844

## through-bolts

M5ncr

normal standard



M5x42

6640 L 107846

M5ncr

auf Wunsch  
on request



M5x66

Die Schrauben können der Türstärke angepaßt werden.  
The screws can be adjusted to the door thickness.

für **Einsteckschlösser**  
for mortise locks

außen  
outside

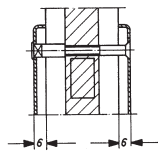

innen  
inside

**Türstärke**  
door thickness  
35-40mm

**Schraubenlängen 6640 K**  
screw-length  
42mm (Standard)

außen  
outside

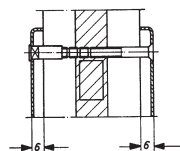

innen  
inside

**Türstärke**  
door thickness  
22-28mm  
29-34mm  
35-42mm  
43-46mm  
47-52mm  
53-58mm  
59-64mm

**Schraubenlängen 6640 L**  
screw-length  
30mm  
36mm  
42mm  
48mm  
54mm  
60mm  
66mm

Wenn die Türstärke nicht angegeben ist, wird die Standard-Länge geliefert.  
If the door thickness is not indicated, the standard-length will be delivered.

<b>3211 Z</b>	<b>Einsteckschloß</b>		
	<b>mortise lock</b>		
links	rechts		
left hand	right hand		
107191	107192	Mmch	
107195	107196	Mp	
107193	107194	Mpch	

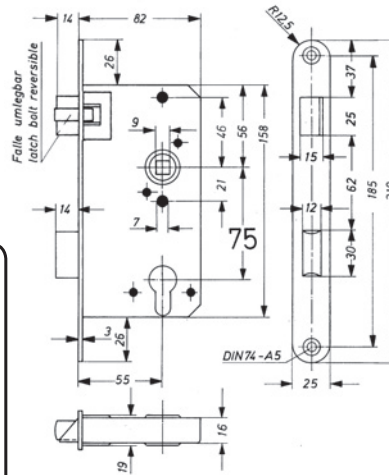

**3211 Z**  
rechts

3201 Z + 3211 Z  
 auf Wunsch: a) mit Sperrhakenloch  
 b) mit Wechsel  
 on request: a) with hole for ajarhook  
 b) with latch lever  
 auf Wunsch: verschiedene Dornmaße von 40-100 mm möglich  
 on request: different backsets from 40-100 mm possible  
 auf Wunsch: verschiedene Stulpabmessungen möglich  
 on request: different faceplate dimensions possible

<b>3201 Z</b>	<b>Einsteckschloß</b>		
	<b>mortise lock</b>		
links	rechts		
left hand	right hand		
107405	107406	Mmch	
107403	107404	Mp	
107407	107408	Mpch	

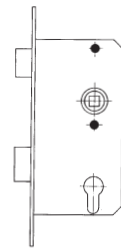

3201 Z

Dornmaße Messing/  
backset brass  
40/45/55/60/65/70/75/80/85/90/95/100

<b>3211 F</b>	<b>Einsteckfallenschloß</b>		
	<b>mortise latch lock</b>		
links	rechts		
left hand	right hand		
107209	107210	Mmch	
107213	107214	Mp	
107211	107212	Mpch	

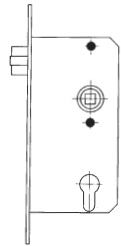

3211 F

<b>3201 F</b>	<b>Einsteckfallenschloß</b>		
	<b>mortise latch lock</b>		
links	rechts		
left hand	right hand		
107387	107388	Mmch	
107385	107386	Mp	
107389	107390	Mpch	

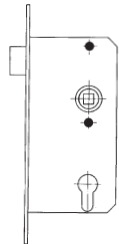

3201 F

<b>3226</b>	<b>Schließblech</b>		
	<b>striking plate</b>		
links	rechts		
left hand	right hand		
107501	100117	Mmch	
101363	110119	Mp	
101362	110118	Mpch	

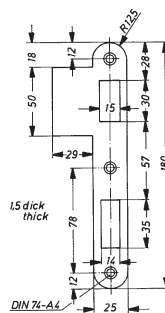

3226  
rechts

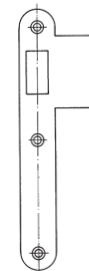

3226 F



<b>3226F</b>	<b>Schließblech</b>		
	<b>striking plate</b>		
links	rechts		
left hand	right hand		
107375	107376	Mmch	
107373	107374	Mp	
107377	107378	Mpch	

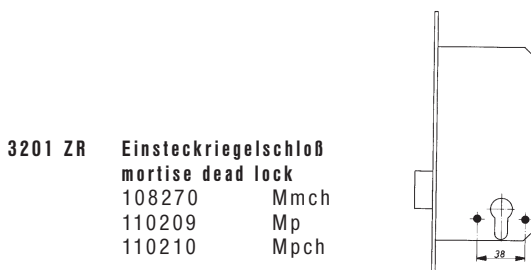

3201 ZR

<b>3241</b>	<b>Schließblech</b>		
	<b>striking plate</b>		
100127	Mmch		
100129	Mp		
100128	Mpch		

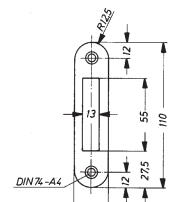

3241

<b>6645 Z/75</b>	<b>Kurzschilder mit Zylinderloch</b> short door plates with cylinder hole		<b>Paar</b> pair
101292		Mmch	
101296		Mp	
101295		Mpch	
<b>6645 Z/1/75</b>	<b>Kurzschild mit Zylinderloch</b> short door plate with cylinder hole		<b>Stück</b> piece
106942		Mmch	
106941		Mp	
106943		Mpch	
<b>6645 Z/2/75</b>	<b>Kurzschild mit Zylinderloch</b> short door plate with cylinder hole		<b>Stück</b> piece
106939		Mmch	
106938		Mp	
106940		Mpch	

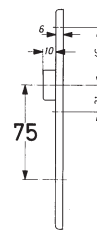

**6645 Z/75**  
**6645 Z/1/75**    **6645 Z/2/75**

<b>6643 Z/75</b>	<b>Kurzschilder mit Zylinderloch</b> short door plates with cylinder hole		<b>Paar</b> pair
101640		Mmch	
101642		Mp	
101641		Mpch	
<b>6643 Z/1/75</b>	<b>Kurzschild mit Zylinderloch</b> short door plate with cylinder hole		<b>Stück</b> piece
106791		Mmch	
106792		Mp	
106790		Mpch	
<b>6643 Z/2/75</b>	<b>Kurzschild mit Zylinderloch</b> short door plate with cylinder hole		<b>Stück</b> piece
106794		Mmch	
106795		Mp	
106793		Mpch	

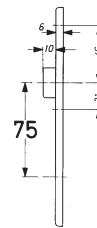

**6643 Z/75**  
**6643 Z/2/75**    **6643 Z/1/75**

<b>3343 Z/75</b>	<b>Langschild mit Zylinderloch</b> long door plate with cylinder hole	
101281		Mmch
101283		Mp
101282		Mpch

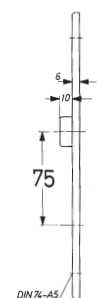





**3343 Z/75**

Alle Schilder auch als F-Schild  
All plates also available as F-plate



**Kurzschilder/1 mit eckigen Löchern werden mit 2 Hülsenschrauben geliefert.  
Short door plates/1 with square holes are accompanied by 2 through bolts.**

normal  M5x42  
standard  M5x66  
auf Wunsch  M5x42  
on request  M5x66

**6645 WCP/75** Kurzschild  
short plate  
106978 Mmch  
106977 Mp  
106979 Mpch

**6645 WCR/1/75** Kurzschild mit rot-grün-Scheibe  
short plate with red-green indicator  
106975 Mmch  
106974 Mp  
106976 Mpch

**6645 WCO/2/75** Kurzschild mit Olive  
short plate with thumbturn  
106971 Mmch  
106972 Mp  
106973 Mpch

**6643 WCP/75** Kurzschilder  
short plates  
106831 Mmch  
106832 Mp  
106830 Mpch

**6643 WCR/1/75** Kurzschild mit rot-grün-Scheibe  
short plate with red-green indicator  
106828 Mmch  
106829 Mp  
106827 Mpch

**6643 WCO/2/75** Kurzschild mit Olive  
short plate with thumbturn  
106825 Mmch  
106826 Mp  
106824 Mpch

**3343 WCP/75** Langschilder  
long plates  
109145 Mmch  
117222 Mp  
117223 Mpch

**3343 WCR/75** Langschild mit rot-grün-Scheibe  
long plate with red-green indicator  
100309 Mmch  
100311 Mp  
100310 Mpch

**3343 WCO/75** Langschild mit Olive  
long plate with thumbturn  
100306 Mmch  
100308 Mp  
100307 Mpch

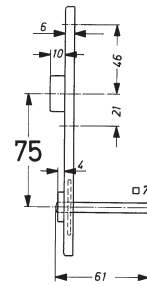

6645 WCP/75  
6645 WCO/2/75 6645 WCR/1/75

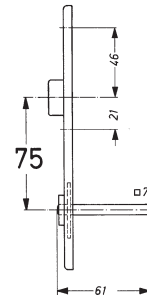

6643 WCP/75  
6643 WCO/2/75 6643 WCR/1/75

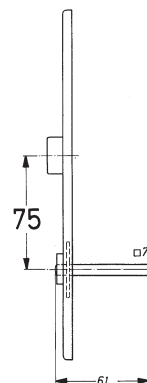

3343 WCP/75  
3343 WCO/75 3343 WCR/75

bei Einsteckschlössern			
normal:	<input type="checkbox"/> Stift Länge	61 mm	für Türstärke 35-42 mm
auf Wunsch:		69 mm	43-50 mm
oder:		77 mm	51-58 mm
for mortise locks			
standard:	square spanner length	61 mm	for door thickness 35-42 mm
on request:		69 mm	43-50 mm
or:		77 mm	51-58 mm



**3811 Z** Einsteckschloß  
mortise lock  
links rechts  
left hand right hand  
117230 117231

Estr pol

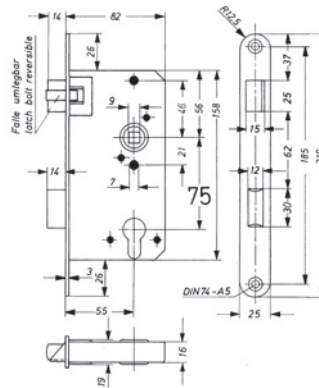

**3811 Z**

**3801 Z** Einsteckschloß  
mortise lock  
links rechts  
left hand right hand  
117246 117247

Estr pol

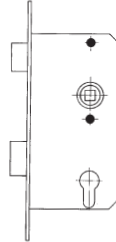

**3801 Z**

**3811 F** Einsteckfallenschloß  
mortise latch  
links rechts  
left hand right hand  
117232 117233

Estr pol

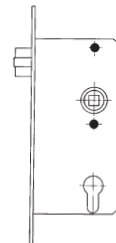

**3811 F**

**3801 F** Einsteckfallenschloß  
mortise latch  
links rechts  
left hand right hand  
117248 117249

Estr pol

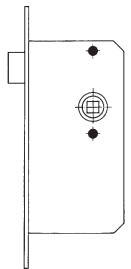

**3801 F**

**5626** Schließblech  
striking plate  
links rechts  
left hand right hand  
113803 113804

Estr pol

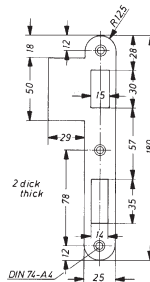

**5626 rechts**



**5626**

**5626 F** Schließblech  
striking plate  
links rechts  
left hand right hand  
113805 113806

Estr pol

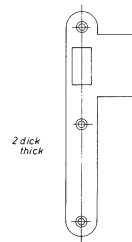

**5626 F links**

Dornmaße Edelstahl/  
backset stainless steel  
55/60/65/70/75/80/85/90/95/100

**3801 ZR** Einsteckriegelschloß  
mortise dead lock  
111782 Estr pol

3801 Z + 3801 ZR  
auf Wunsch: a) mit Sperrhakenloch  
b) mit Wechsel (nur bei Z)  
on request: a) with hole for ajarhook  
b) with latch lever (only cylinder)

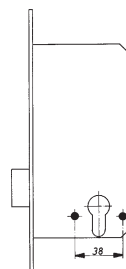

**3801 ZR**

**3241** Schließblech  
striking plate  
10128 Mpch

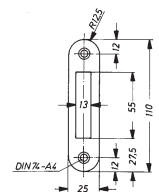

**3241**



- 6645 Z/75** Kurzschilder mit Zylinderloch  
short door plates with cylinder hole  
113091
- 6645 Z/1/75** Kurzschild mit Zylinderloch  
short door plate with cylinder hole  
113090
- 6645 Z/2/75** Kurzschild mit Zylinderloch  
short door plate with cylinder hole  
113092

Estr pol  
Estr pol  
Estr pol

Paar  
paar  
Stück  
piece  
Stück  
piece

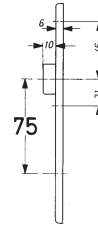

**6645 Z/75**  
**6645 Z/1/75**    **6645 Z/2/75**

- 6643 Z/75** Kurzschilder mit Zylinderloch  
short door plates with cylinder hole  
113750
- 6643 Z/1/75** Kurzschild mit Zylinderloch  
short door plate with cylinder hole  
117224
- 6643 Z/2/75** Kurzschild mit Zylinderloch  
short door plate with cylinder hole  
115260

Estr pol  
Estr pol  
Estr pol

Paar  
paar  
Stück  
piece  
Stück  
piece

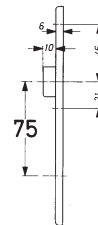

**6643 Z/75**  
**6643 Z/2/75**    **6643 Z/1/75**

- 3343 Z/75** Langschild mit Zylinderloch  
long door plate with cylinder hole  
113577

Estr pol

Stück  
piece

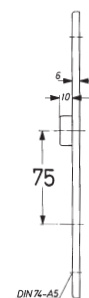

**3343 Z/75**

Alle Schilder auch als F-Schild  
All plates also available as F-plate





**Kurzschilder/1 mit eckigen Löchern werden mit 2 Hülsenschrauben geliefert.  
Short door plates/1 with square holes are accompanied by 2 through bolts.**

normal standard auf Wunsch  
on request

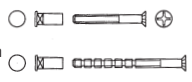

M5x42 M5x66

**6645 WCP/75** Kurzschilder  
short plates  
117238 Estr pol Paar  
pair

**6645 WCR/1/75** Kurzschild mit rot-grün-Scheibe  
short plate with red-green indicator  
117239 Estr pol Stück  
piece

**6645 WCO/2/75** Kurzschild mit Olive  
short plate with thumbturn  
117240 Estr pol Stück  
piece

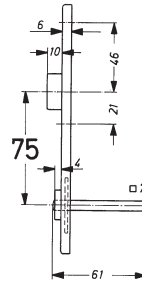

**6645 WCP/75**  
**6645 WCO/2/75 6645 WCR/1/75**

**6643 WCP/75** Kurzschilder  
short plates  
117242 Estr pol Paar  
pair

**6643 WCR/1/75** Kurzschild mit rot-grün-Scheibe  
short plate with red-green indicator  
117243 Estr pol Stück  
piece

**6643 WCO/2/75** Kurzschild mit Olive  
short plate with thumbturn  
115261 Estr pol Stück  
piece

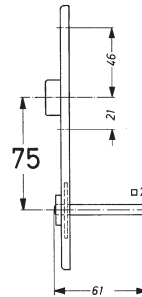

**6643 WCP/75**  
**6643 WCO/2/75 6643 WCR/1/75**

**3343 WCR/75** Langschild mit rot-grün-Scheibe  
long plate with red-green indicator  
117244 Estr pol Stück  
piece

**3343 WCO/75** Langschild mit Olive  
long plate with thumbturn  
117245 Estr pol Stück  
piece

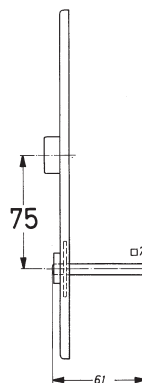

**3343 WCO/75 3343 WCR/75**

bei Einsteckschlössern

normal: □Stift Länge

auf Wunsch:

oder:

for mortise locks

standard: square spanner length

on request:

or:

61 mm für Türstärke

69 mm

77 mm

61 mm for door thickness

69 mm

77 mm

35-42 mm

43-50 mm

51-58 mm

35-42 mm

43-50 mm

51-58 mm

4410  
**Drücker  
 handles**  
 106346  
 106348  
 106347

Mmch  
 Mp  
 Mpch

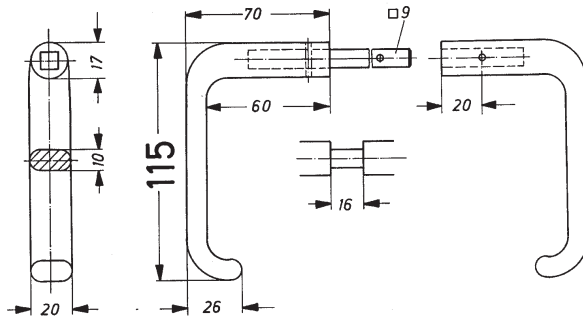

4410

2210  
**Drücker  
 handles**  
 112239

Estr pol

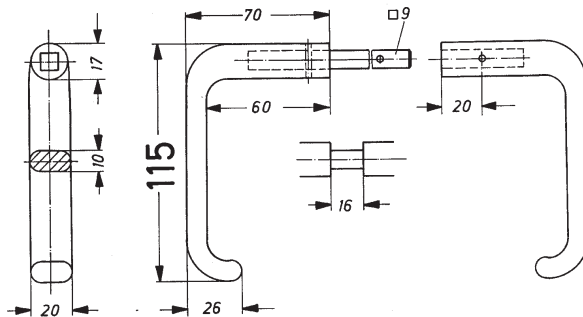

2210

3310  
**Drücker  
 handles**  
 106353  
 106355  
 106354

Mmch  
 Mp  
 Mpch

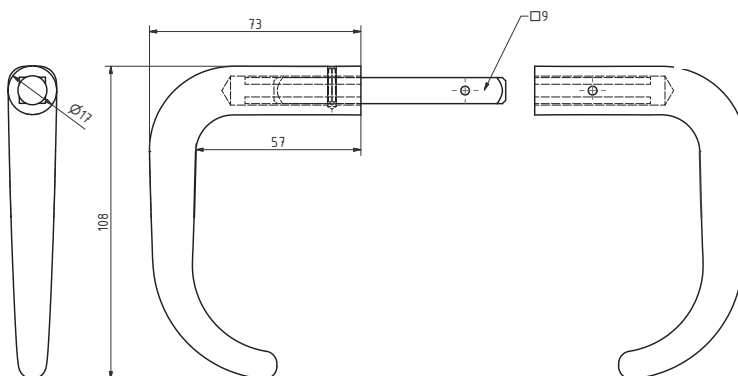

3310



**Dreifallenschloß für 55 mm Dornmaß**  
**three point lock for 55 mm backset**

bestehend aus:  
 1 Einsteckschloß (ZM)  
 2 Zusatzfallenschlösser (FOU)  
 für oben und unten  
 ohne Stange  
 consisting of:  
 1 mortise lock (ZM)  
 2 additional latches (FOU)  
 for above and below  
 without flat bar

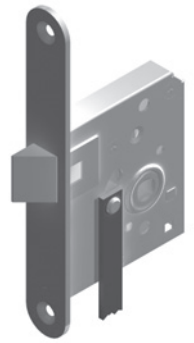
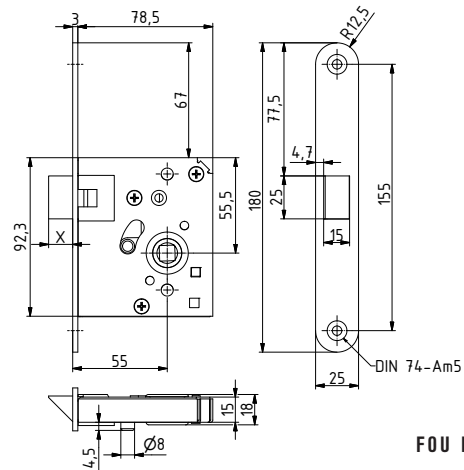

**FOU links/left hand**

**2436 ZM Hauptschloß center Lock**  
 x = 16 mm Fallenausschluss latch protrusion  
 links rechts  
 left hand right hand  
 113103 113104

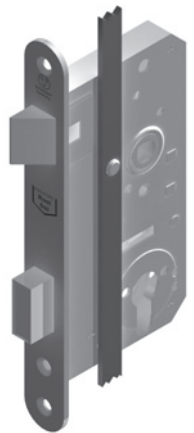
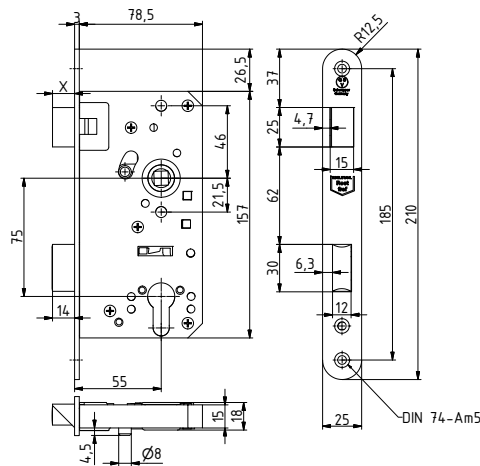

**ZM links/left hand**

**2436 FOU Zusatzfallenschloß additional latch**  
 x = 16 mm Fallenausschluss latch protrusion  
 links rechts  
 left hand right hand  
 113107 113108

**2438 ZM Hauptschloß center Lock**  
 x = 14 mm Fallenausschluss latch protrusion  
 links rechts  
 left hand right hand  
 111298 111299

**2438 FOU Zusatzfallenschloß additional latch**  
 x = 14 mm Fallenausschluss latch protrusion  
 links rechts  
 left hand right hand  
 111296 111297

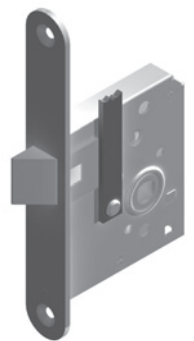
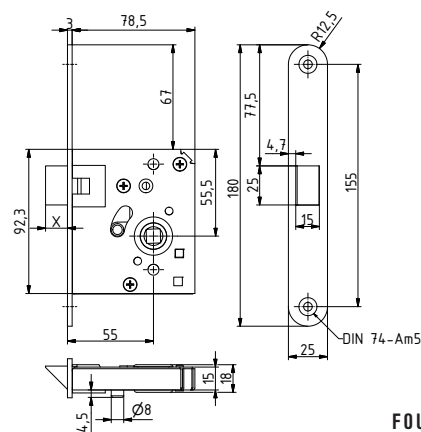

**FOU links/left hand**

**2439 ZM Hauptschloß center Lock**  
 x = 19 mm Fallenausschluss latch protrusion  
 links rechts  
 left hand right hand  
 113584 113585

**2439 FOU Zusatzfallenschloß additional latch**  
 x = 19 mm Fallenausschluss latch protrusion  
 links rechts  
 left hand right hand  
 113586 113587

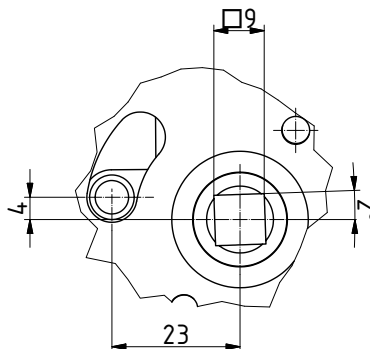

Ausführung Edelstahl poliert lieferbar  
 Stainless steel polished available



**Dreifallenschloß für 65 mm Dornmaß**  
**three point lock for 65 mm backset**

bestehend aus:  
 1 Einsteckschloß (ZM)  
 2 Zusatzfallenschlösser (FOU)  
 für oben und unten  
 ohne Stange  
 consisting of:  
 1 mortise lock (ZM)  
 2 additional latches (FOU)  
 for above and below  
 without flat bar

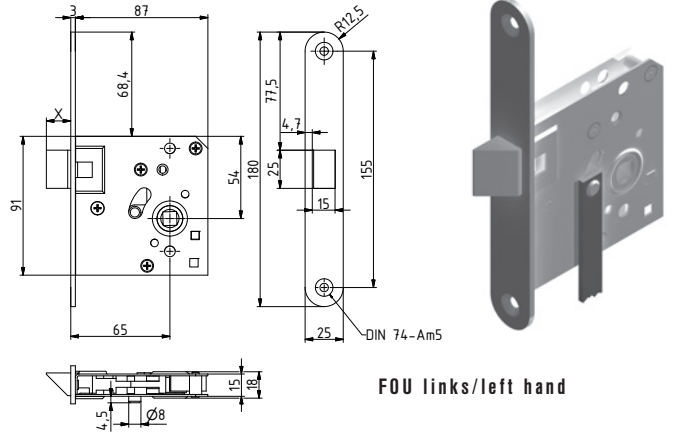

FOU links/left hand

**2436 ZM Hauptschloß**  
**center Lock**  
 x = 16 mm Fallenausschluss  
 latch protrusion  
 links rechts  
 left hand right hand  
 113592 113593

**2436 FOU Zusatzfallenschloß**  
**additional latch**  
 x = 16 mm Fallenausschluss  
 latch protrusion  
 links rechts  
 left hand right hand  
 113594 113595

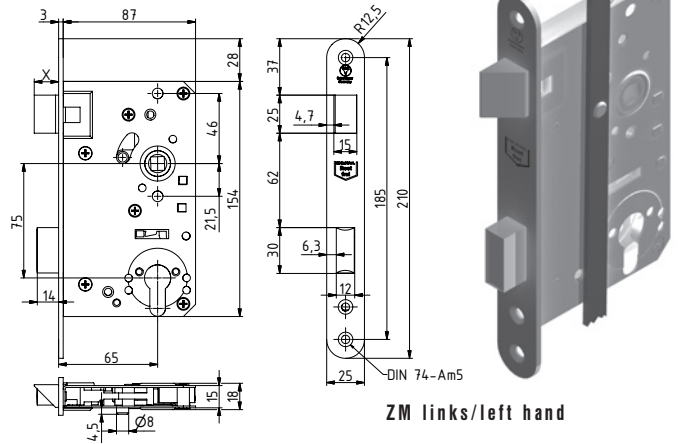

ZM links/left hand

**2438 ZM Hauptschloß**  
**center Lock**  
 x = 14 mm Fallenausschluss  
 latch protrusion  
 links rechts  
 left hand right hand  
 113588 113589

**2438 FOU Zusatzfallenschloß**  
**additional latch**  
 x = 14 mm Fallenausschluss  
 latch protrusion  
 links rechts  
 left hand right hand  
 113590 113591

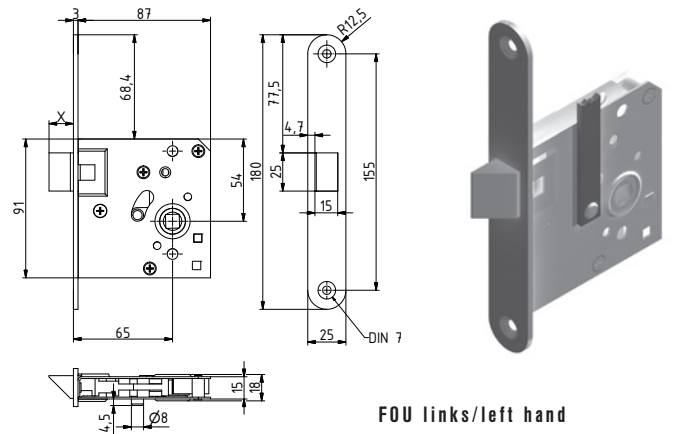

FOU links/left hand

**2439 ZM Hauptschloß**  
**center Lock**  
 x = 19 mm Fallenausschluss  
 latch protrusion  
 links rechts  
 left hand right hand  
 113582 113583

**2439 FOU Zusatzfallenschloß**  
**additional latch**  
 x = 19 mm Fallenausschluss  
 latch protrusion  
 links rechts  
 left hand right hand  
 113580 113581

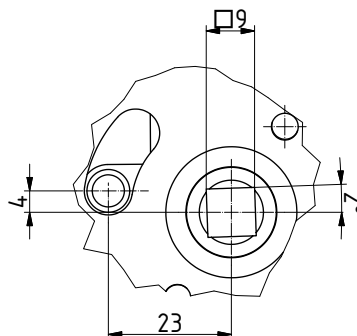

Ausführung Edelstahl poliert lieferbar  
 Stainless steel polished available

<b>968</b>	<b>Einsteckschloß</b>		
	<b>mortise lock</b>		
	links	rechts	
	left hand	right hand	
	103957	103958	Mp
103953	103954	Mmch	
103955	103956	Mpch	

64 verschiedene Schließungen  
64 different keyings

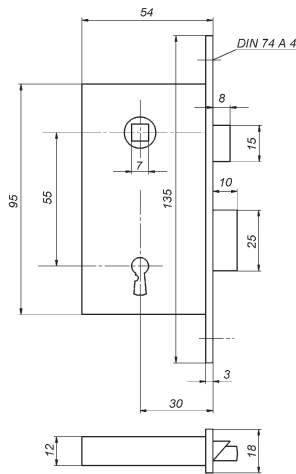

**968**

<b>923</b>	<b>Schließblech</b>		
	<b>striking plate</b>		
	links	rechts	
	left hand	right hand	
	103975	103976	Mp
103971	103972	Mmch	
103973	103974	Mpch	

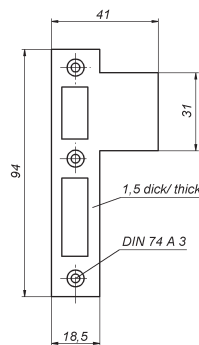

**923**

<b>968 WC</b>	<b>Einsteck-WC-Schloß</b>		
	<b>mortise toilet lock</b>		
	links	rechts	
	left hand	right hand	
	103969	103970	Mp
103965	103967	Mmch	
103966	103968	Mpch	



**968 WC**

<b>5620 S</b>	<b>Vierkantschlüssel innen 5mm</b>
	<b>square spanner inside 5mm</b>
	104073



**5620 S**

<b>968 F</b>	<b>Einsteckfallenschloß</b>		
	<b>mortise latch</b>		
	links	rechts	
	left hand	right hand	
	103963	103964	Mp
103959	103960	Mmch	
103961	103962	Mpch	



**968 F**

<b>923 F</b>	<b>Schließblech</b>		
	<b>striking plate</b>		
	links	rechts	
	left hand	right hand	
	107999	108000	Mp
108001	108002	Mmch	
108003	108004	Mpch	

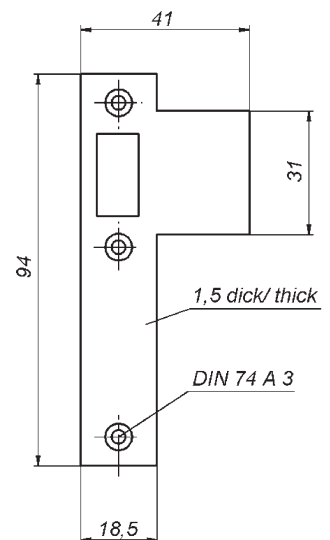

**923 F**



**968 Z** Einsteckschloß mit Doppelzylinder  
mortise lock with double cylinder  
links rechts  
left hand right hand  
110979 110982 Mp  
110980 110983 Mmch  
110981 110984 Mpch

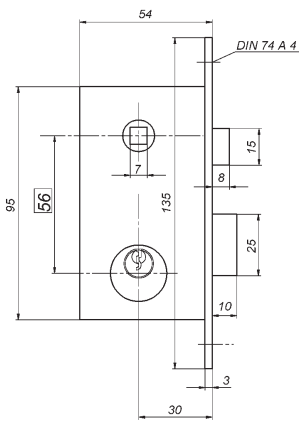
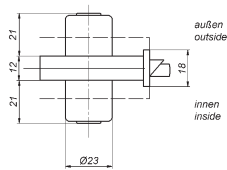

968 Z

Zwei gleichschließende Zylinder werden von beiden Seiten nach dem Einstecken des Schloßes montiert und mittels 2 Schrauben befestigt.  
Two cylinders keying alike will be added after mortising of lock case and fixed with 2 screws.

**968 ZK** Einsteckschloß mit Knaufzylinder  
mortise lock with thumbturn cylinder  
links rechts  
left hand right hand  
110985 110988 Mp  
110986 110989 Mmch  
110987 110990 Mpch

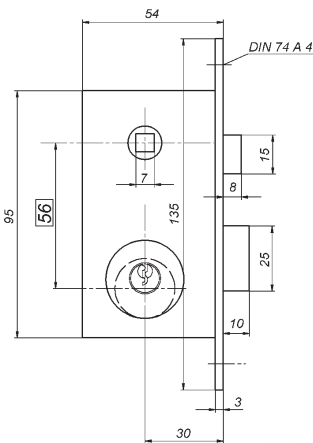
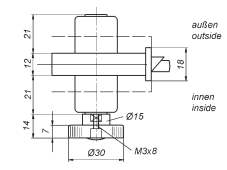

968 ZK

Zwei gleichschließende Zylinder werden von beiden Seiten nach dem Einstecken des Schloßes montiert und mittels 2 Schrauben befestigt.  
Nach Befestigung der Schilder wird der Knauf montiert mit einer Befestigungsschraube und Verschlussstopfen.  
Two cylinders keying alike will be added after mortising of lock case and fixed with 2 screws.  
After fixing of the door plates the knob will be mounted with a fixing screw and a cover plug.

**923** Schließblech  
striking plate  
links rechts  
left hand right hand  
103975 103976 Mp  
103971 103972 Mmch  
103973 103974 Mpch

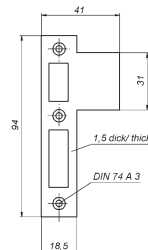

923 links

2 Hülsenschrauben M4  
normal für Türstärke 30-36 mm  
auf Wunsch für andere Türstärken

2 through bolts M4  
standard for door thickness 30-36 mm  
on request for other door thickness



**5968 Z** Drücker mit 2 Schildern  
handles with 2 plates  
110991 Mp  
110992 Mmch  
110993 Mpch

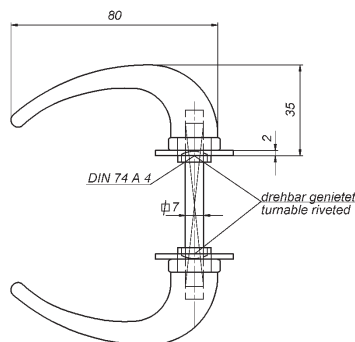

**1968 Z** Knopfdrücker mit 2 Schildern  
knob handles with 2 plates  
110994 Mp  
110995 Mmch  
110996 Mpch

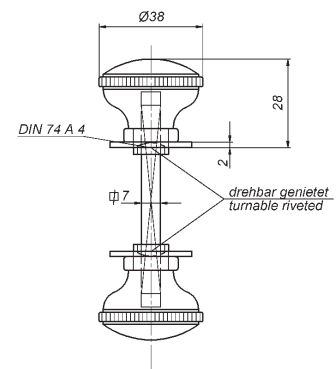

auf Wunsch:  
alle Garnituren mit Ringdrücker (außen)  
on request:  
all sets with ring handles (outside)  
= 5968 ZR, 1968 ZR

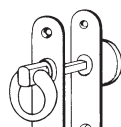



<b>928</b>	<b>Kastenschloß</b> <b>rim lock</b>				
	links	links	rechts	rechts	
	einwärts	auswärts	einwärts	auswärts	
	left hand	left hand	right hand	right hand	
	inward	outward	inward	outward	
	104006	104007	104004	104005	
	103998	103999	103996	103997	
	104002	104003	104000	104001	

Mp  
Mmch  
Mpch

64 verschiedene Schließungen  
64 different keyings

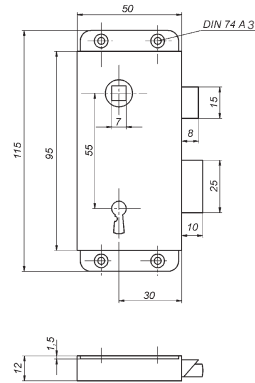

928

<b>923</b>	<b>Schließblech</b> <b>striking plate</b>			
	links	rechts		
	left hand	right hand		
	103975	103976		
	103971	103972		
	103973	103974		

Mp  
Mmch  
Mpch

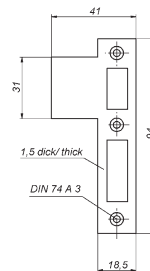

923

<b>922</b>	<b>Schließkasten</b> <b>striking box</b>			
	104010			
	104008			
	104009			

Mp  
Mmch  
Mpch

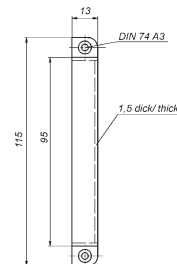

922

<b>928 FWC</b>	<b>Kasten-WC-Schloß</b> <b>rim toilet lock</b>			
	links und rechts verwendbar			
	left and right hand usable			
	104025			
	104023			
	104024			

Mp  
Mmch  
Mpch

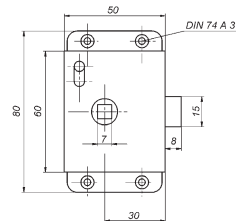

928 FWC

<b>928 F</b>	<b>Kastenfallenschloß</b> <b>rim latch</b>			
	links und rechts verwendbar			
	left and right hand usable			
	101304			
	101302			
	101303			

Mp  
Mmch  
Mpch

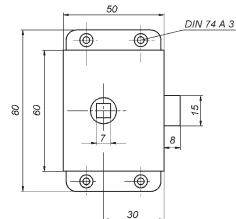

928 F

<b>925</b>	<b>Schließblech</b> <b>striking plate</b>			
	104031	Mp		
	104029	Mmch		
	104030	Mpch		

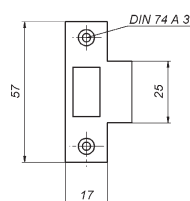

924

**Schließkasten**  
**striking box**

104028	Mp
104026	Mmch
104027	Mpch

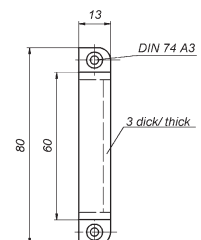

**5928** Drücker mit 1 Schild  
handles with 1 plate  
104034  
104032  
104033

Mp  
Mmch  
Mpch

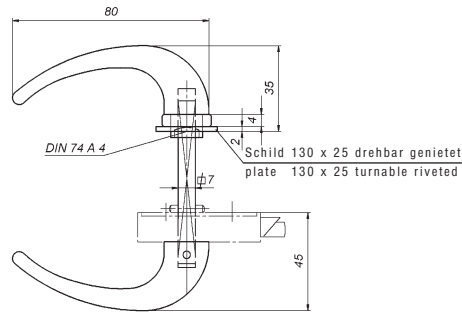

**5928**

**1928** Knopfdrücker mit 1 Schild  
knob handles with 1 plate  
104037  
104035  
104036

Mp  
Mmch  
Mpch

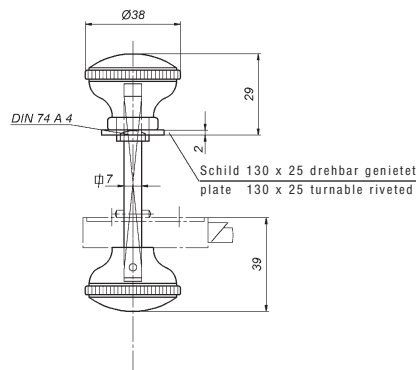

**1928**

**5928 F** Drücker mit 1 Schild  
handles with 1 plate  
104040  
104038  
104039

Mp  
Mmch  
Mpch

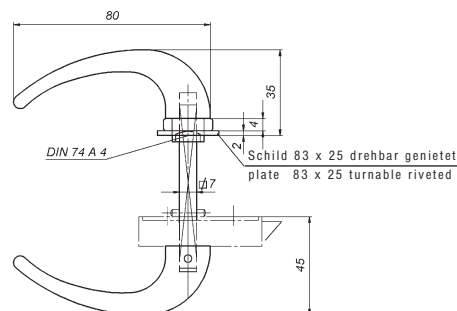

**5928 F**

**1928 F** Knopfdrücker mit 1 Schild  
knob handles with 1 plate  
104043  
104041  
104042

Mp  
Mmch  
Mpch

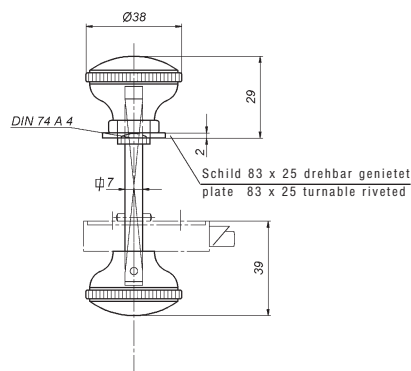

**1928 F**

Stiftlänge normal für Türstärke 18 - 25 mm  
auf Wunsch für andere Türstärken

square length standard for door thickness 18 - 25 mm  
on request for other door thickness

**928 ZK Kastenschloß mit Knauf und Zylinder rim lock with thumbturn and cylinder**

links	links	rechts	echts	
einwärts	auswärts	einwärts	auswärts	
left hand	left hand	right hand	right hand	
inward	outward	inward	outward	
111004	111007	111010	111013	Mp
111005	111008	111011	111014	Mmch
111006	111009	111012	111015	Mpch

L = Zylinder / cylinder  
normal / standard

auf Wunsch / on request:

oder / or

Ø 23 x 21 mm für Türstärke 15 - 18mm  
for door thickness

Ø 23 x 25mm für Türstärke 19 - 22mm  
for door thickness

Ø 23 x 30mm für Türstärke 23 - 27mm

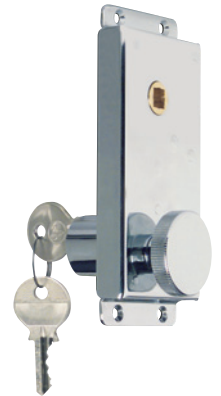
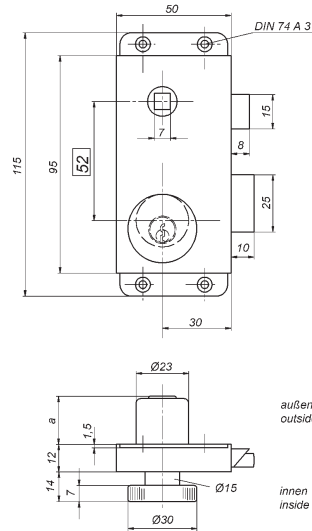

928 ZK

**923 Schließblech striking plate**

links	rechts	
left hand	right hand	
103975	103976	Mp
103971	103972	Mmch
103973	103974	Mpch

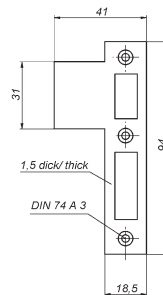

923

**922 Schließkasten striking box**

104010	Mp
104008	Mmch
104009	Mpch

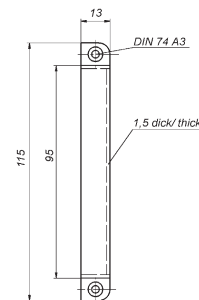

922

**5928 Z Drücker mit 1 Schild handles with 1 plate**

111016	Mp
111017	Mmch
111018	Mpch

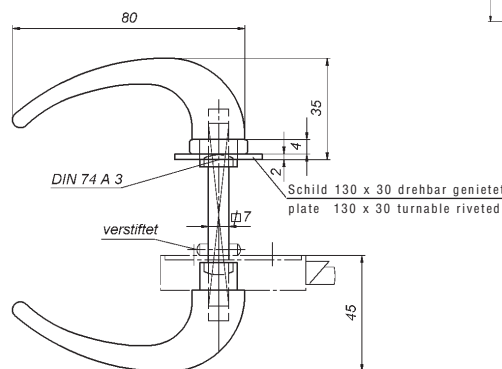

**1928 Z Knopfdrücker mit 1 Schild knob handles with 1 plate**

111020	Mp
111021	Mmch
111022	Mpch

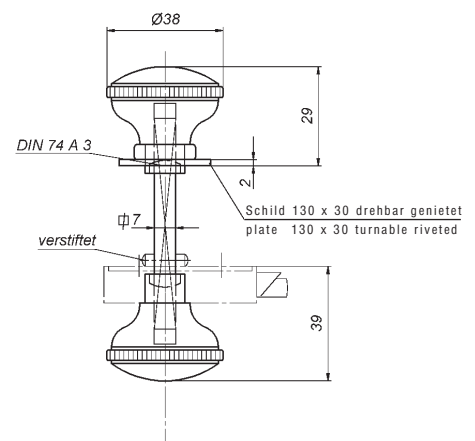

2 Hülsenschrauben M5  
normal für Türstärke 28-36 mm  
auf Wunsch für andere Türstärken

2 through bolts M5  
standard for door thickness 28-36 mm  
on request for other door thickness



3269

**Einsteckfallenschloß  
mit Drückern und 2 Schildern**  
**mortise latch  
with handles and 2 plates**  
links und rechts verwendbar  
left and right hand usable  
100236  
100234  
100235

Mp  
Mmch  
Mpch



3269

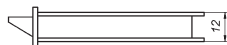
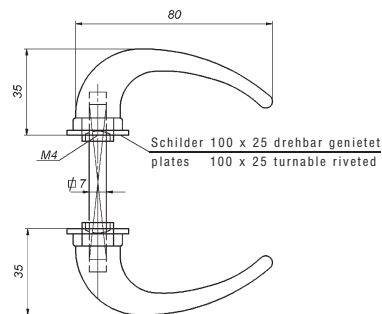
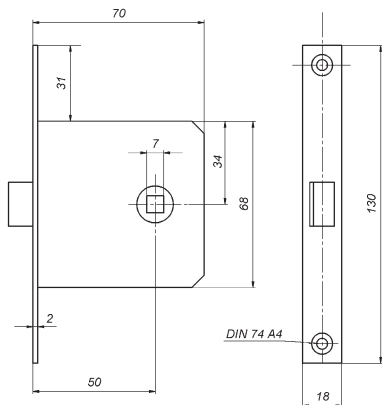

3269 A

**Einsteckfallenschloß  
mit Dreholiven und 2 Schildern**  
**mortise latch  
with turn handles and 2 plates**  
links und rechts verwendbar  
left and right hand usable  
100239  
100237  
100238

Mp  
Mmch  
Mpch



3269 A

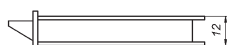
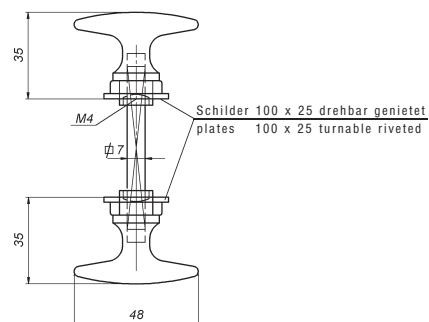
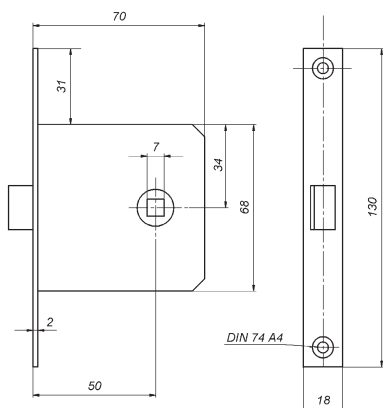

2 Schrauben M4  
normal für Türstärke 30-36 mm  
auf Wunsch für andere Türstärken

2 screws M4  
standard for door thickness 30-36 mm  
on request for other door thickness



**3269 DK** Einsteckfallenschloß  
mit Drückern und 2 Rosetten  
mortise latch  
with handles and 2 roses  
links und rechts verwendbar  
left and right hand usable  
110831  
110461  
110832

Mp  
Mmch  
Mpch



**3269 DK**

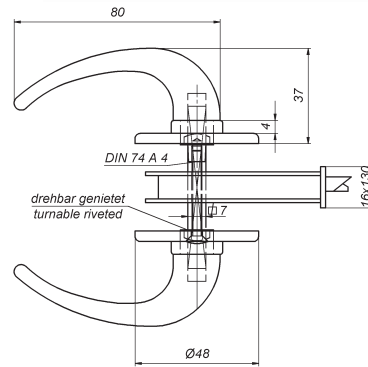
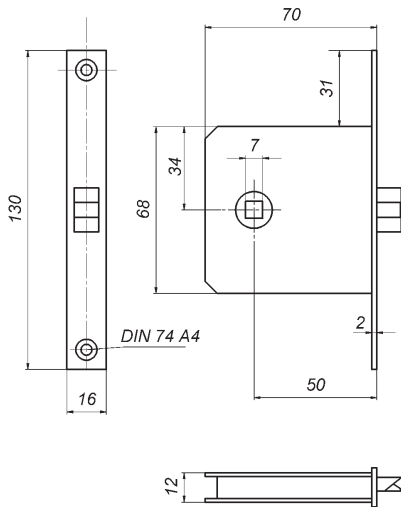

**3928 F** Kastenfallenschloß  
mit Drückern und 1 Rosette  
rim latch  
with handles and 1 rose  
links und rechts verwendbar  
left and right hand usable  
109120  
104125  
109121

Mp  
Mmch  
Mpch



**3928 F**

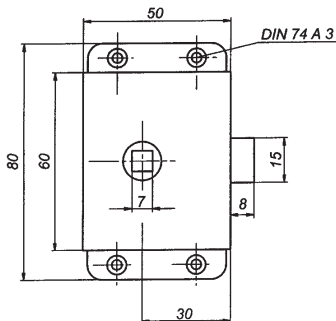

Vierkantstift mit Kerbstift  
Square spindle with pin

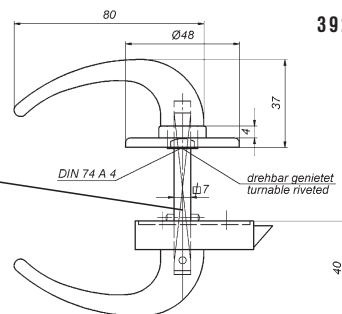

Stiftlänge normal für Türstärke 18 - 25 mm  
auf Wunsch für andere Türstärken

square length standard for door thickness 18 - 25 mm  
on request for other door thickness

<b>4040 Z</b>	<b>Einsteckschloß</b> <b>mortise lock</b>			
Dornmaß	links	rechts		
backset	left hand	right hand		
40 mm	101552	101551		
	100248	100247		
	101550	100249		
50 mm	101555	101554		
	100251	100250		
	101553	100252		

Profilzylinder Seite Y-25  
profile cylinders page Y-25

Mp  
Mmch  
Mpch  
Mp  
Mmch  
Mpch

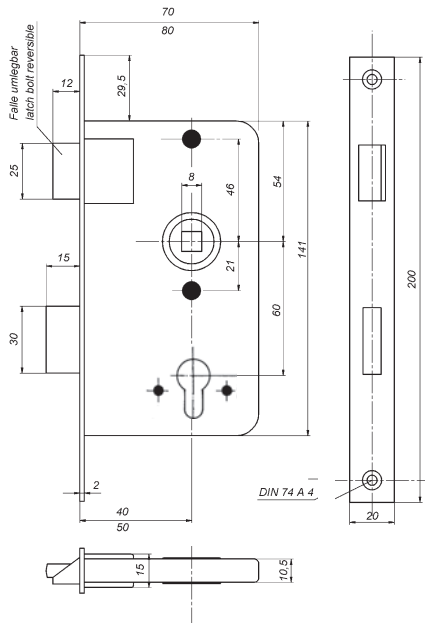

4040 Z

<b>4040</b>	<b>Einsteckschloß mit 2 Schlüsseln</b> <b>mortise lock with 2 keys</b>			
Dornmaß	links	rechts		
backset	left hand	right hand		
40 mm	101546	101545		
	100242	100241		
	101544	100243		
50 mm	101549	101548		
	100245	100244		
	101547	100246		

120 verschiedene Schließungen  
120 different keyings

Mp  
Mmch  
Mpch  
Mp  
Mmch  
Mpch

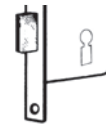

4040

<b>4026</b>	<b>Schließblech</b> <b>striking plate</b>			
links	rechts			
left hand	right hand			
107337	107338			
107339	107340			
107341	107342			

Mp  
Mmch  
Mpch

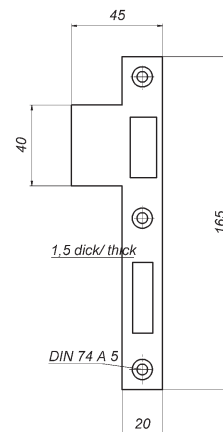

4026

<b>4040 WC</b>	<b>Einsteck-WC-Schloß</b> <b>mortise toilet lock</b>			
Dornmaß	links	rechts		
backset	left hand	right hand		
40 mm	101564	101563		
	100260	100259		
	101562	100261		
50 mm	101567	101566		
	100263	100262		
	101565	100264		

Mp  
Mmch  
Mpch  
Mp  
Mmch  
Mpch

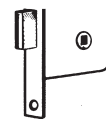

4040 WC

<b>4040 F</b>	<b>Einsteckfallenschloß</b> <b>mortise latch</b>			
Dornmaß	links	rechts		
backset	left hand	right hand		
40 mm	101558	101557		
	100254	100253		
	101556	100255		
50 mm	101561	101560		
	100257	100256		
	101559	100258		

Mp  
Mmch  
Mpch  
Mp  
Mmch  
Mpch

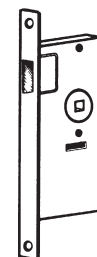

4040 F

<b>4026 F</b>	<b>Schließblech</b> <b>striking plate</b>			
links	rechts			
left hand	right hand			
107343	107344			
107345	107346			
107347	107348			

Mp  
Mmch  
Mpch

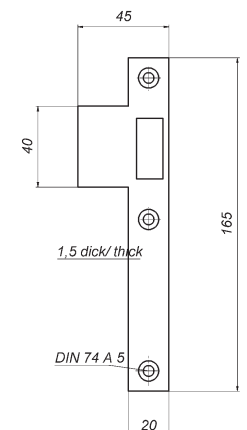

4026 F

<b>4529</b>	<b>Vierkantschlüssel innen</b> <b>square spanner inside 7mm</b>	<b>7 mm</b>	
	100297		Mmch

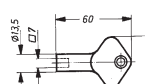

<b>4040 ZK</b>	<b>Einsteckschloß</b> <b>mortise lock</b>		
Dornmaß	links	rechts	
backset	left hand	right hand	
40 mm	111592	111593	
	111594	111595	
	111596	111597	
50 mm	111598	111599	
	111600	111601	
	111602	111603	

Profilzylinder Seite Y-25  
profile cylinders page Y-25

<b>4040 K</b>	<b>Einsteckschloß mit 2 Schlüssel</b> <b>mortise lock with 2 keys</b>		
Dornmaß	links	rechts	
backset	left hand	right hand	
40 mm	111568	111569	
	111570	111571	
	111572	111573	
50 mm	111574	111575	
	111616	111577	
	111578	111579	

120 verschiedene Schließungen  
120 different keyings

<b>4026</b>	<b>Schließblech</b> <b>striking plate</b>		
links	rechts		
left hand	right hand		
107337	107338		
107339	107340		
107341	107342		

<b>4040 WCK</b>	<b>Einsteck-WC-Schloß</b> <b>mortise toilet lock</b>		
Dornmaß	links	rechts	
backset	left hand	right hand	
40 mm	111604	111605	
	111606	111607	
	111608	111609	
50 mm	111610	111611	
	111612	111613	
	111614	111615	

<b>4040 FK</b>	<b>Einsteckfallenschloß</b> <b>mortise latch</b>		
Dornmaß	links	rechts	
backset	left hand	right hand	
40 mm	111580	111581	
	111582	111583	
	111584	111585	
50 mm	111586	111587	
	111588	111589	
	111590	111591	

<b>4026 F</b>	<b>Schließblech</b> <b>striking plate</b>		
links	rechts		
left hand	right hand		
107343	107344		
107345	107346		
107347	107348		

<b>4529</b>	<b>Vierkantschlüssel innen</b> <b>square spanner inside</b>	<b>7 mm</b>	
	100297		

Mp  
Mmch  
Mpch  
Mp  
Mmch  
Mpch

Mp  
Mmch  
Mpch  
Mp  
Mmch  
Mpch

Mp  
Mmch  
Mpch

Mp  
Mmch  
Mpch  
Mp  
Mmch  
Mpch

Mp  
Mmch  
Mpch  
Mp  
Mmch  
Mpch

Mp  
Mmch  
Mpch

Mmch

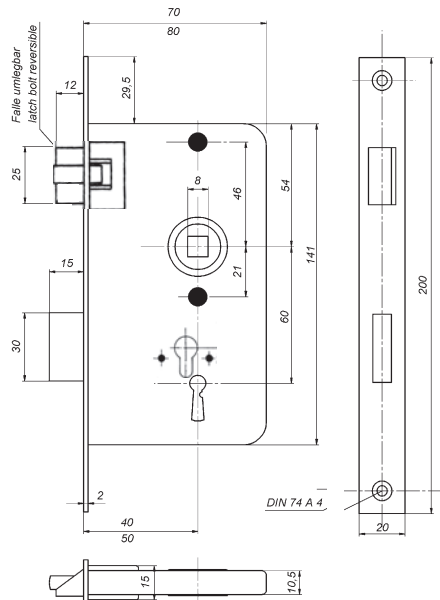

4040 ZK

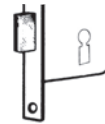

4040 K

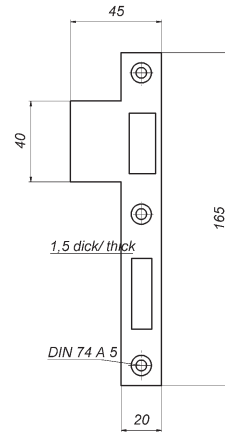

4026

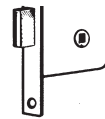

4040 WC K

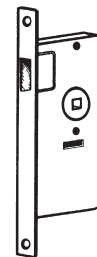

4040 FK

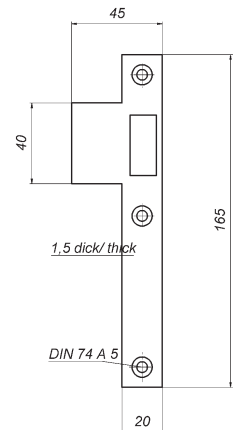

4026 F

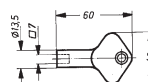

**1069 Z** Einsteck-Schiebetürschloß  
mortise sliding door lock  
100374  
100372  
100373

Mp  
Mmch  
Mpch

Profilzylinder Seite Y - 25  
profile cylinders page Y - 25

Stulp  
face plate

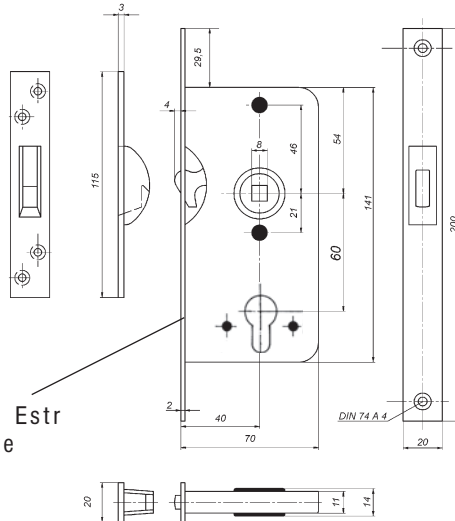

1069 Z

**1069** Einsteck-Schiebetürschloß  
mortise sliding door lock  
100371  
100369  
100370

Mp  
Mmch  
Mpch

120 verschiedene Schließungen  
120 different keyings



1069

**1069 WC** Einsteck-WC-Schiebetürschloß  
mortise toilet sliding door lock  
100380  
100378  
100379

Mp  
Mmch  
Mpch



1069 WC

**4529** Vierkantschlüssel innen  
square spanner inside 7 mm  
100297

Mmch

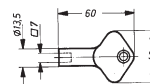

**1069 F** Einsteck-Schiebetürfallenschloß  
mortise sliding door latch  
100377  
100375  
100376

Mp  
Mmch  
Mpch



1069 F

passende Drückergarnituren Serien 5969  
matching handle sets series 5969



**969 Z** Einsteck-Schiebetürschloß  
mortise sliding door lock  
117691 Mp/PVD  
117692 Mmch  
117693 Mpch

Profilzylinder Seite Y - 25  
profile cylinders page Y - 25

Hakenfalle + Schließblech Edestahl rostfrei  
Hook + strike stainless steel

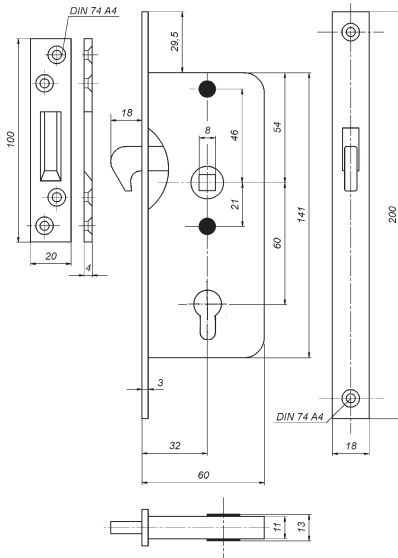

969 Z

**969** Einsteck-Schiebetürschloß  
mortise sliding door lock  
103918 Mp  
103916 Mmch  
103917 Mpch

120 verschiedene Schließungen  
120 different keyings

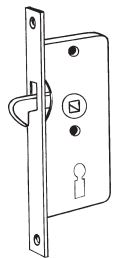

969

**969 WC** Einsteck-WC-Schiebetürschloß  
mortise toilet sliding door lock  
117697 Mp/PVD  
117698 Mmch  
117699 Mpch

Hakenfalle + Schließblech Edestahl rostfrei  
Hook + strike stainless steel

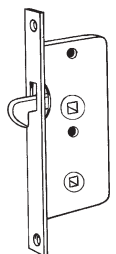

969 WC

**4529** Vierkantschlüssel innen 7 mm  
square spanner inside 7mm  
100297 Mmch

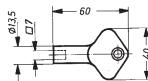

**969 F** Einsteck-Schiebetürfallenschloß  
mortise sliding door latch  
117688 Mp/PVD  
117689 Mmch  
117690 Mpch

Hakenfalle + Schließblech Edestahl rostfrei  
Hook + strike stainless steel

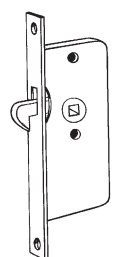

969 F

passende Drückergarnituren Serien 5969  
matching handles sets series 5969

3 Hülsenschrauben M4  
normal für Türstärke 36 - 42 mm  
auf Wunsch für andere Türstärken

3 through bolts M4  
standard for door thickness 36 - 42 mm  
on request for other door thickness



**5969 Z** Drücker mit 2 Schildern  
handles with 2 plates  
103933  
103931  
103932

Mp  
Mmch  
Mpch

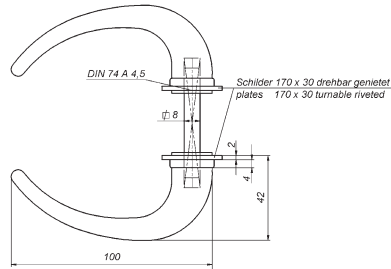
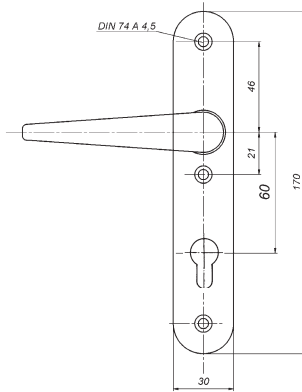

**5969**

**5969** Drücker mit 2 Schildern  
handles with 2 plates  
103930  
103928  
103929

Mp  
Mmch  
Mpch

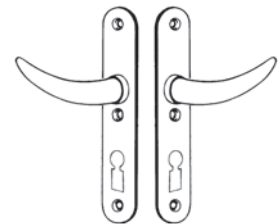

**5969 Z**

**5969 WC** Drücker mit 2 Schildern  
handles with 2 plates  
103940  
103937  
103939

Mp  
Mmch  
Mpch

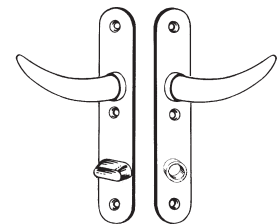

**5969 WC**

**5969 F** Drücker mit 2 Schildern  
handles with 2 plates  
103936  
103934  
103935

Mp  
Mmch  
Mpch

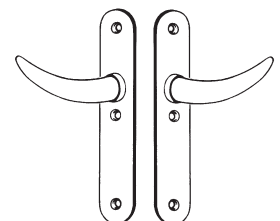

**5969 F**

Diese Garnituren passen zu Serie 4040 (Drücker waagrecht)  
und zu Serien 1069 und 969 (Drücker senkrecht)  
These sets are matching with series 4040 (handles horizontal)  
and with series 1069 and 969 (handles vertical)

Oberflächen Mmch / Mp / Mpch lieferbar  
 Finishes Mmch / Mp / Mpch available

**Profilzylinder für Schlösser 4040Z, 969Z, 1069Z**  
**profile cylinder for locks 4040Z, 969Z, 1069Z**

**seewasserbeständig**  
 mit Messing-Schließbart 7,7 mm  
 mit 3 Neusilber-Schlüsseln

**seawater resistant**  
 with brass locking cam 7,7 mm  
 with 3 keys of nickel-silver

Halbzylinder  
 single cylinder



337/7,7

Doppelzylinder  
 double cylinder



353/7,7

Knaufzylinder sind in 3 verschiedenen Varianten lieferbar:  
 thumbturn-cylinders are available in 3 versions:

Standard  
 mit Knauf 5502  
 standard  
 with thumbturn 5502

Knaufzylinder  
 thumbturn cylinder

383/7,7



5502

auf Wunsch  
 mit Knauf 5602  
 on request  
 with thumbturn 5602



5602

oder  
 mit Knauf 5762  
 or  
 with thumbturn 5762



5762

Bitte angeben:  
 Zylinder-Type (Nr.)  
 Schloß-Type (Nr.)  
 Türstärke wegen Zylinderlänge  
 und Zylinderteilung

Please state:  
 type of cylinder (No.)  
 type of lock (No.)  
 door thickness for cylinder length  
 and cylinder sharing

**Zylinder-Vorhangschloß**  
 Messing vernickelt  
 mit 3 Neusilber-Schlüsseln  
**cylinder-padlock**  
 brass nickel plated  
 with 3 keys nickel-silver

in Schließanlagen lieferbar, auch in  
 Kombination mit Profilzylindern  
 in lock systems available, also in  
 combination with profile cylinders



5830

Schließanlagen auf Anfrage  
 lock systems on request

Profilzylinder und Möbelzylinder mit  $\varnothing 23$  mm können mit gleichen Schlüsseln aus PZ-Anlagen bedient werden, vorausgesetzt, daß die Möbelzylinder mindestens 30 mm lang sind. Somit ist die Integration von Möbelzylindern in PZ-Anlagen möglich.

Profile cylinders and cylinders for cabinet locks with  $\varnothing 23$  mm can be operated with the same keys, provided that the cabinet lock cylinders have a length of minimum 30 mm. Thus the integration of cabinet lock cylinders in profile cylinder systems is possible.

**3271 Möbelschloß mit 3 Zuhaltungen**  
**cabinet lock with 3 lever tumblers**

Dornmaß links/links lad rechts/rechts lad  
 backset left/left drawer right/right drawer

	Mp	Mmch	Mpch	Mp	Mmch	Mpch
20 mm	101726	101720	101723	101724	101719	101721
25 mm	101735	101729	101732	101734	101728	101731
30 mm	101744	101738	101741	101743	101737	101740
35 mm	101753	101747	101750	101752	101746	101749
40 mm	101762	101756	101759	101761	101755	101758

76 verschiedene Schließungen  
 76 different keyings

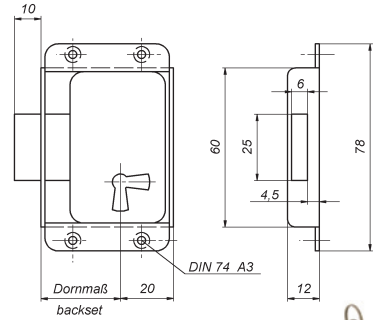

3271

**3273 Möbelschloß mit 3 Zuhaltungen**  
**cabinet lock with 3 lever tumblers**

Dornmaß links, rechts und lad brauchbar  
 backset left hand, right hand and for drawers usable

	Mp	Mmch	Mpch
20 mm	101769	101767	101768
25 mm	101772	101770	101771
30 mm	101775	101773	101774
35 mm	101778	101776	101777

76 verschiedene Schließungen  
 76 different keyings

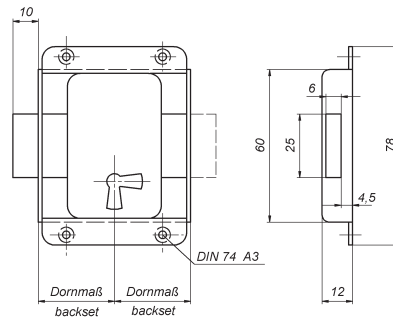

3273

**3272 A Schließblech**  
**striking plate**

Mp	Mmch	Mpch
107526	107527	107528

**3272 B Winkelschließblech**  
**angular striking plate**

Mp	Mmch	Mpch
107556	107557	107558

**3272 C Winkelschließblech**  
**angular striking plate**

Mp	Mmch	Mpch
107559	107560	107561

**3272 F Winkelschließblech**  
**angular striking plate**

Mp	Mmch	Mpch
110872	109835	110873

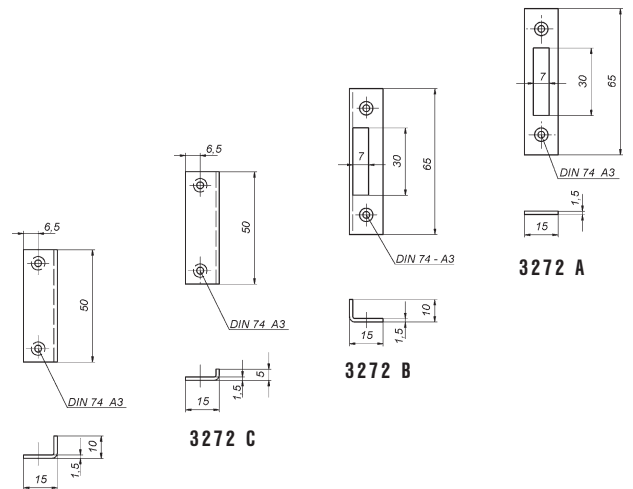

3272 A

3272 B

3272 C

3272 F

**3275 Möbelschloß mit 3 Zuhaltungen**  
**cabinet lock with 3 lever tumblers**

Mp	Mmch	Mpch
101766	101764	101765

27 verschiedene Schließungen  
 27 different keyings

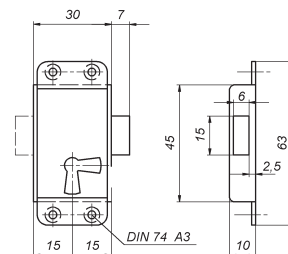

3275

**3272 D Schließblech**  
**striking plate**

Mp	Mmch	Mpch
107520	107521	107522

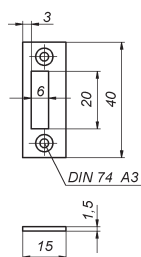

3272 D

**3736 Schlüsselschild Ø32 x 1,25 mm**  
**keyhole escutcheon**

Mp	Mmch	Mpch
101971	101969	101970



3736

3271 Z

**Möbelschloß**  
**cabinet lock**  
 mit Zylinder und Rosette  
 with cylinder and rose

Dornmaß links/left hand

backset	Mp	Mmch
20 mm	101795	101789
25 mm	101804	101798
30 mm	101813	101807
35 mm	101822	101815
40 mm	107107	107111

rechts/right hand

backset	Mp	Mmch	Mpch
20 mm	101794	101788	101791
25 mm	101803	101797	101800
30 mm	101812	101806	101809
35 mm	101821	101816	101818
40 mm	107108	107112	107110

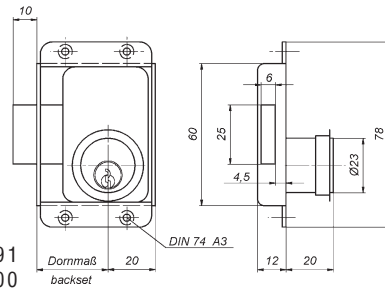

3271 Z

normal für Türstärke bis 20 mm

auf Wunsch mit längerem Zylinder für Türstärke bis 25 mm  
 oder für Türstärke bis 30 mm

normal for door thickness up to 20 mm

on request with longer cylinder for door thickness up to 25 mm  
 or for door thickness up to 30 mm

3271 Z lad

**Möbelschloß**  
**cabinet lock**  
 mit Zylinder und Rosette  
 with cylinder and rose-

Dornmaß links und rechts brauchbar

backset	Mp	Mmch	Mpch
17 mm	101796	101790	101793
22 mm	101805	101799	101802
27 mm	101814	101808	101811
32 mm	101823	101817	101820

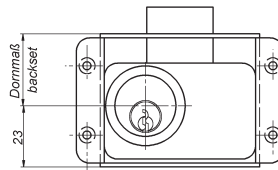

normal für Türstärken bis 20 mm

auf Wunsch mit längerem Zylinder für Türstärke bis 25 mm  
 oder für Türstärke bis 30 mm

normal for door thickness up to 20 mm

on request with longer cylinder for door thickness up to 25 mm  
 or for door thickness up to 30 mm

3273 Z

**Möbelschloß**  
**cabinet lock**  
 mit Zylinder und Rosette  
 with cylinder and rose

Dornmaß links und rechts brauchbar

backset left hand and right hand usable

backset	left hand	right hand	usable
20 mm	101826	101824	101825
25 mm	101829	101827	101828
30 mm	101832	101830	101831

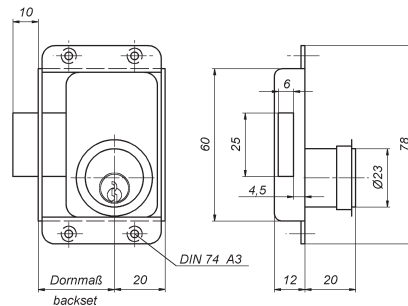

3273 Z

normal für Türstärken bis 20 mm

auf Wunsch mit längerem Zylinder für Türstärke bis 25 mm  
 oder für Türstärke bis 30 mm

normal for door thickness up to 20 mm

on request with longer cylinder for door thickness up to 25 mm  
 or for door thickness up to 30 mm

4309

**Möbelschnäpper**  
**cabinet latch**  
 mit Dreholive  
 links und rechts brauchbar

with olive handle

left and right hand usable

101839 Mp

101837 Mmch

101838 Mpch

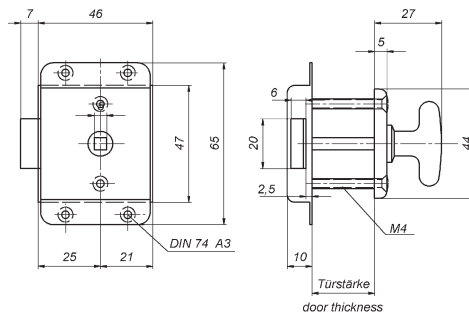

4309

normal für Türstärke 18 - 23 mm

auf Wunsch für Türstärken zwischen 10 und 40 mm

normal for door thickness 18 - 23 mm

on request for door thickness between 10 and 40 mm

- 6039 Z** **Möbelschloß mit Zylinder**  
**cabinet lock with cylinder**  
 mit Knopfschild 30mm breit  
 with knob plate 30mm wide  
 links rechts  
 left hand right hand  
 101913 101911 Mp  
 101908 101906 Mmch  
 101910 101909 Mpch

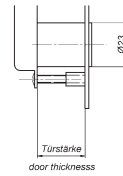
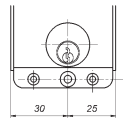

76 verschiedene Schließungen  
 76 different keyings

**6039 Z**  
 normal für Türstärken bis 18 mm  
 auf Wunsch mit längerem Zylinder für Türstärke bis 23 mm  
 oder für Türstärke bis 28 mm  
 normal for door thickness up to 18 mm  
 on request with longer cylinder for door thickness up to 23 mm  
 or for door thickness up to 28 mm

- 6039** **Möbelschloß mit 3 Zuhaltungen und 2 Schlüsseln**  
**cabinet lock with 3 lever tumblers and 2 keys**  
 mit Knopfschild 30 mm breit  
 with knob plate 30 mm wide  
 links rechts  
 left hand right hand  
 101904 101903 Mp  
 101898 101897 Mmch  
 101901 101900 Mpch

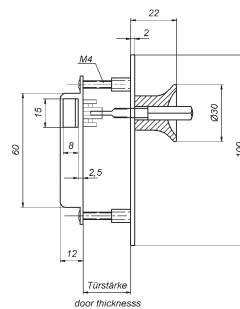
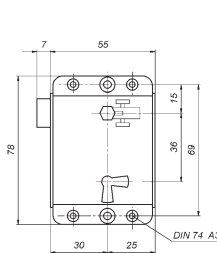

76 verschiedene Schließungen  
 76 different keyings

- 6039 Z lad** **Möbelschloß mit Zylinder**  
**cabinet lock with cylinder**  
 mit Knopfschild 35 mm breit  
 with knob plate 35 mm wide  
 101914 Mp  
 101907 Mmch  
 101912 Mpch

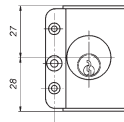

normal für Türstärken bis 18 mm  
 auf Wunsch mit längerem Zylinder für Türstärke bis 23 mm  
 oder für Türstärke bis 28 mm  
 normal for door thickness up to 18 mm  
 on request with longer cylinder for door thickness up to 23 mm  
 or for door thickness up to 28 mm

- 6039 lad** **Möbelschloß mit 3 Zuhaltungen und 2 Schlüsseln**  
**cabinet lock with 3 lever tumblers and 2 keys**  
 mit Knopfschild 30mm breit  
 with knob plate 30mm wide  
 101905 Mp  
 101899 Mmch  
 101902 Mpch

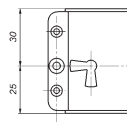

- 3533** **Möbelschlüssel ohne Einschnitte**  
**cabinet key without cuttings**  
 101928 Mmch

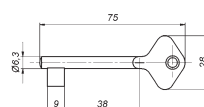

**3533**

- 5845** **Möbelschloß mit Zylinder**  
**cabinet lock with cylinder**  
 110641 Estr Kasten  
 case  
 Estr Unterlegplatte  
 intermedial plate  
 Alel Griffschale  
 grip plate

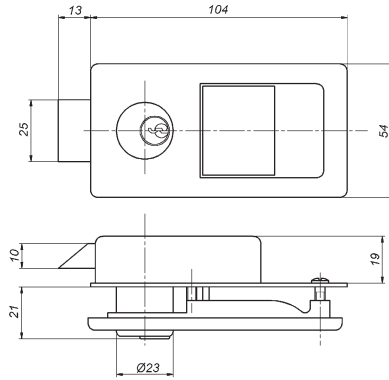

5845

- 110641: mit Zylinder Ø 23 x 21 mm für Türstärke 15 - 18 mm  
 with cylinder Ø 23 x 21 mm for door thickness 15 - 18 mm  
 111368: mit Zylinder Ø 23 x 25 mm für Türstärke 19 - 23 mm  
 with cylinder Ø 23 x 25 mm for door thickness 19 - 23 mm

- 5845 S** **Möbelschloß mit Zylinder**  
**cabinet lock with cylinder**  
 auch von der Rückseite zu verriegeln und zu öffnen  
 also from backside to lock and to open  
 110833 Mmch Kasten  
 case  
 Estr Unterlegplatte  
 intermedial plate  
 Alel Griffschale  
 grip plate



5845 S

- 5846** **Möbelschloß nicht abschließbar**  
**cabinet lock not lockable**  
 107588 Mmch Kasten  
 case  
 Estr Unterlegplatte  
 intermedial plate  
 Alel Griffschale  
 grip plate

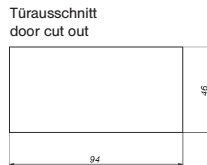

5846

normal für Türstärke 15 mm  
 standard for door thickness 15 mm  
 auf Wunsch bis 39 mm  
 on request up to 39 mm

- 5847** **Möbelschloß mit Druckknopf für Hängschloß**  
**cabinet lock with push knob for padlock**  
 107586 Mmch Kasten  
 case  
 Estr Unterlegplatte  
 intermedial plate  
 Alel Griffschale  
 grip plate

nur für Türstärke 17 - 20 mm  
 only for door thickness 17 - 20 mm

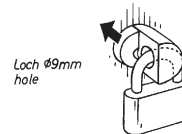

5847

- 3853** **Schließtasche 35 x 21 mm**  
**striking box**  
 108998 Alel

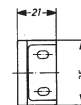
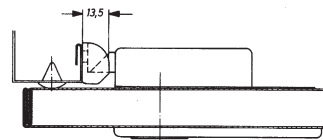

3853

- 3854** **Schließtasche 35 x 30 mm**  
**striking box**  
 108999 Alel

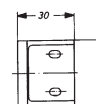
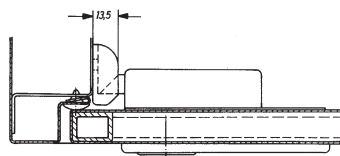

3854

**3518** **Möbelschnäpper mit Knopfschild 50 x 25 mm**  
**cabinet latch with knob plate**  
 links und rechts brauchbar  
 left and right hand usable  
 101874  
 101872  
 101873

Mp  
 Mmch  
 Mpch

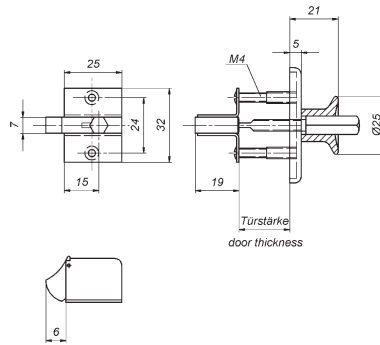

3518

normal für Türstärke 18 und 23 mm  
 auf Wunsch für Türstärke zwischen 13 und 45 mm  
 normal for door thickness 18 and 23 mm  
 on request for door thickness between 13 and 45 mm

**5205** **Möbelschnäpper mit Griff waagrecht/senkrecht**  
**cabinet latch with grip horizontal/vertical**  
 links und rechts brauchbar  
 left and right hand usable  
 104118  
 104116  
 104117

Mp  
 Mmch  
 Mpch

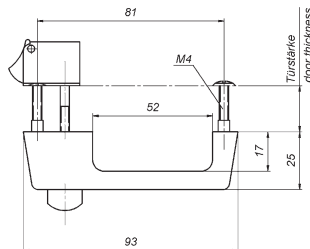

5205

normal für Türstärke 18 - 23mm  
 auf Wunsch für Türstärke zwischen 5 und 36 mm  
 normal for door thickness 18 - 23mm  
 on request for door thickness between 5 and 36 mm

**5205 A** **Möbelgriff**  
**cabinet grip**  
 senkrecht und waagrecht brauchbar  
 vertical and horizontal usable  
 93 mm 104112 Mp  
 104110 Mmch  
 104111 Mpch  
 100 mm 110257 Mp  
 110258 Mmch  
 110259 Mpch

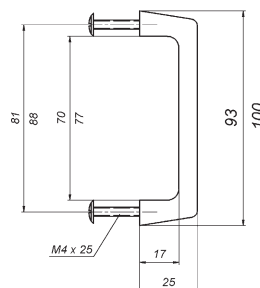

5205 A

normal für Türstärke 15 und 20 mm  
 auf Wunsch für Türstärke zwischen 10 und 45 mm  
 normal for door thickness 15 and 20 mm  
 on request for door thickness between 10 and 45 mm



**4340** **Möbelschnäpper mit Knopfschild 50 x 25 mm**  
**und Schließblech**  
**cabinet latch with knob plate**  
**and strike plate**  
 links und rechts brauchbar  
 left and right hand usable  
 101867  
 101865  
 101866

Mp  
 Mmch  
 Mpch

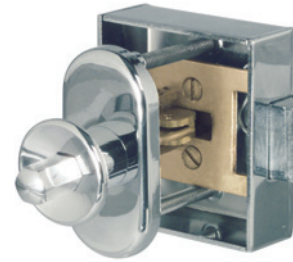
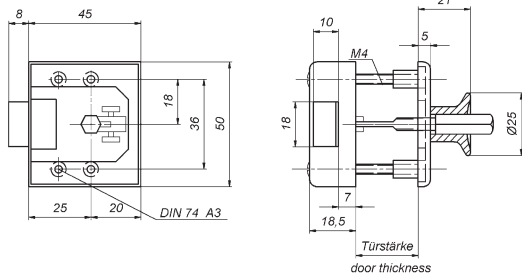

4340

normal für Türstärke 18 und 23 mm  
 auf Wunsch für Türstärke zwischen 13 und 40 mm  
 normal for door thickness 18 and 23 mm  
 on request for door thickness between 13 and 40 mm

**4341** **Möbelschnäpper mit Knopfschild 55 x 30 mm**  
**cabinet latch with knob plate**  
 links und rechts brauchbar  
 left and right hand usable  
 106250  
 106186  
 106249

Mp  
 Mmch  
 Mpch

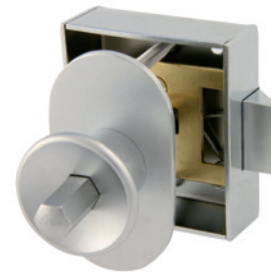
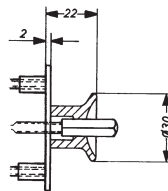

4341

**5605** **Möbelschnäpper mit Griff waagrecht/senkrecht**  
**cabinet latch with grip horizontal/vertical**  
 links und rechts brauchbar  
 left and right hand usable  
 106272  
 106226  
 106271

Mp  
 Mmch  
 Mpch

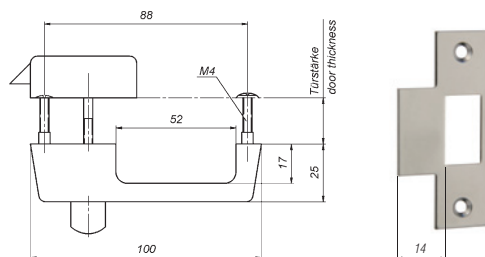

5605

normal für Türstärke 18 und 23 mm  
 auf Wunsch für Türstärke zwischen 5 und 36 mm  
 normal for door thickness 18 and 23 mm  
 on request for door thickness between 5 and 36 mm

**7740**     **Druckschnäpper**  
**push lock**  
 16 mm     110634

Kunststoff matt vernickelt  
 plastic satin nickeled

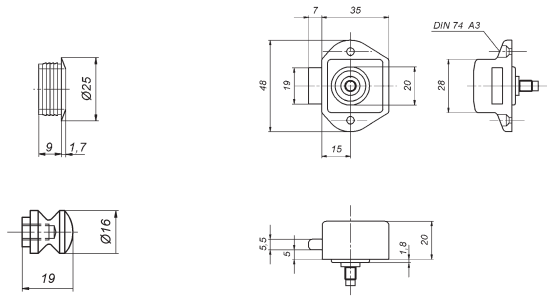

7740

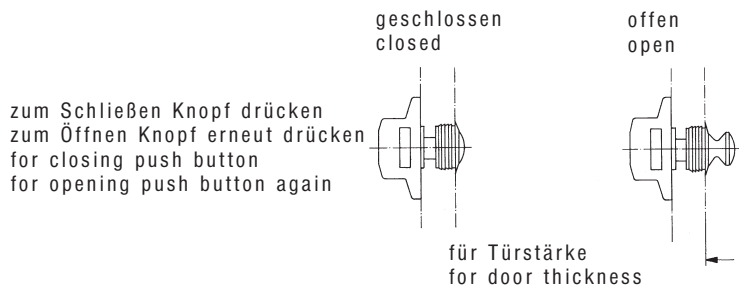

**7741**     **Druckschnäpper**  
**push lock**  
 19 mm     110635  
 25 mm     110636

Kunststoff matt vernickelt  
 plastic satin nickeled

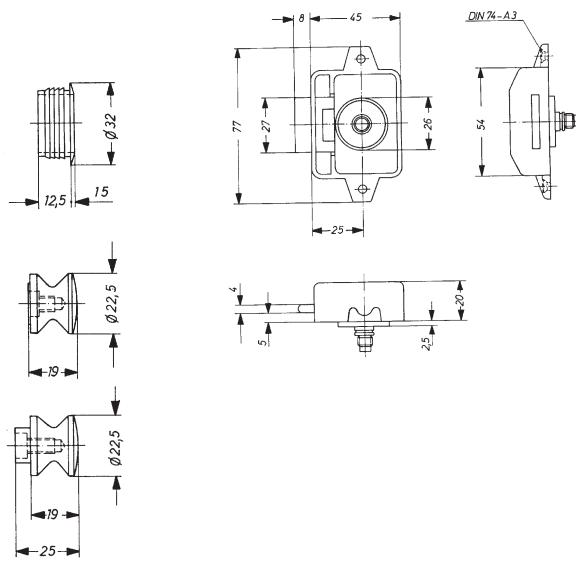

7741

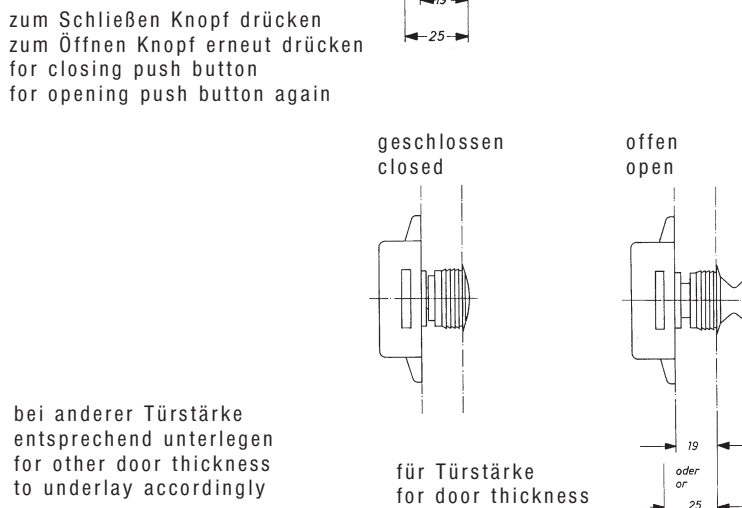

**4146 Möbelhäng 50 mm loose joint hinge**  
 links rechts  
 left hand right hand  
 102237 102238  
 102233 102234  
 102235 102236

Mp  
 Mmch  
 Mpch

für einliegende Tür  
 for recessed door

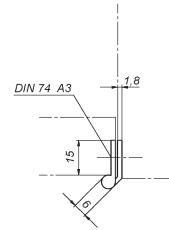

4146

**4186 Möbelscharnier 50 mm cabinet hinge**  
 102241  
 102239  
 102240

Mp  
 Mmch  
 Mpch

rs. + ls. verwendbar

für vorstehende Tür  
 for protruding door

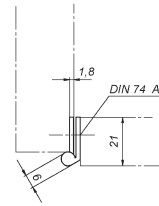

4186

**4346 Möbelhäng 50 mm loose joint hinge**  
 links rechts  
 left hand right hand  
 102255 102256  
 102251 102252  
 102253 102254

Mp  
 Mmch  
 Mpch

für Falztür  
 for rebated door

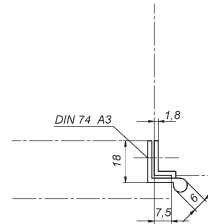

4346

**4386 Möbelscharnier 50 mm cabinet hinge**  
 102259  
 102257  
 102258

Mp  
 Mmch  
 Mpch



4386

**4546 Möbelhäng 50 mm loose joint hinge**  
 links rechts  
 left hand right hand  
 102264 102265  
 102260 102261  
 102262 102263

Mp  
 Mmch  
 Mpch

für Falztür  
 for rebated door

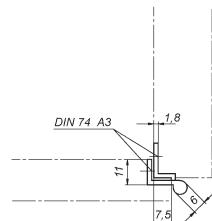

4546

**4586 Möbelscharnier 50 mm cabinet hinge**  
 102268  
 102266  
 102267

Mp  
 Mmch  
 Mpch



4586

**145 Scharnier mit festem Stift**  
**hinge with fixed pin**

Länge length	Breite width	Rollen roll	Ø Ø	Lappenstärke blade thickness	Schraublöcher screw holes	DIN 74 A	Mp	Mmch	Mpch
b	b	d	s	s	Anzahl quantity				
mm	mm	mm	mm	mm					
30	20			1,75	4	3	101310	101308	101309
40	30	5		1,75	4	3	100055	100057	100056
50	40	5		2	6	3	100058	100060	100059
60	50	6		2	6	3,5	100061	100062	100063
65	40	5		2	6	3,5	100064	100066	100065
70	60	7		2,5	6	4,5	100067	100069	100068
80	65	9		3	6	4,5	100070	100072	100071

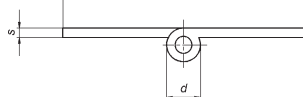

145

**145 A Scharnier mit losem Knopfstift**  
**hinge with loose pin**

Länge length	Breite width	Rollen roll	Ø Ø	Lappenstärke blade thickness	Schraublöcher screw holes	DIN 74 A	Mp	Mmch	Mpch
b	b	d	s	s	Anzahl quantity				
mm	mm	mm	mm	mm					
40	30	5		1,75	4	3	100087	100089	100088
50	40	5		2	6	3	100090	100092	100091
60	50	6		2	6	3,5	100093	100095	100094
65	40	5		2	6	3,5	100096	100098	100097
70	60	7		2,5	6	4,5	100099	100101	100100
80	65	9		3	6	4,5	100102	100104	100103

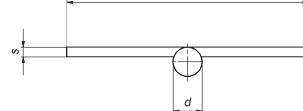

145 A

**193 Türscharnier mit losem Knopfstift oben mit festem Knopf unten**  
**door hinge with loose head-pin above with fixed head below**

80 x 60 mm	109879	Mp
	110269	Mmch
	110884	Mpch
80 x 80 mm	110755	Mp
	110270	Mmch
	110756	Mpch



193

**180 Möbelhäng loose joint hinge**

links left hand	rechts right hand	Mp
40 x 40	101319	Mmch
	101317	Mpch
	101318	Mp
60 x 40	101313	Mmch
	101311	Mpch
	101312	Mpch

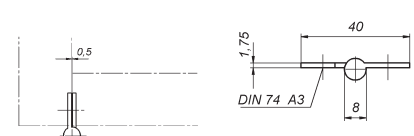

180

**182 Möbelhäng 70 x 50 mm loose joint hinge**

links left hand	rechts right hand	Mp
104050	104051	Mmch
104046	104047	Mpch
104048	104049	Mpch

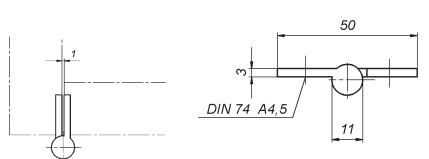

182

**3416 Türhäng 90 x 63 mm loose joint hinge**

links left hand	rechts right hand	Mp
102347	102348	Mmch
102343	102344	Mpch
102345	102346	Mpch

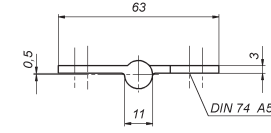

3416  
3417

**3417 Türhäng 100 x 86 mm loose joint hinge**

links left hand	rechts right hand	Mp
102353	102354	Mmch
102349	102351	Mpch
102350	102352	Mpch

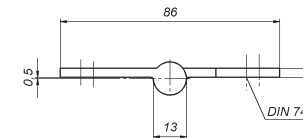

**3038 KH SpannverschuB mit gerader Platte  
fastener with straight plate**

Breite / width 30 mm

110897

110898

110899

Mp

Mmch

Mpch

auf Wunsch / on request:

**mit Winkelplatte A  
with angle plate A**

110900

110901

110902

Mp

Mmch

Mpch

**mit Winkelplatte B  
with angle plate B**

110903

110904

110905

Mp

Mmch

Mpch

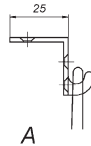

A

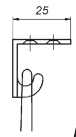

B

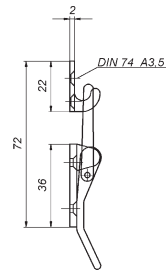

**3038 KH  
mit gerader Platte  
with straight plate**

**3038 K SpannverschuB mit gerader Platte  
fastener with straight plate**

Breite / width 30 mm

102485

102483

102484

Mp

Mmch

Mpch

auf Wunsch / on request:

**mit Winkelplatte A  
with angle plate A**

107589

107590

107591

Mp

Mmch

Mpch

**mit Winkelplatte B  
with angle plate B**

107592

107593

107594

Mp

Mmch

Mpch

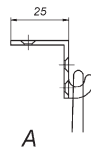

A

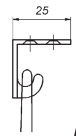

B

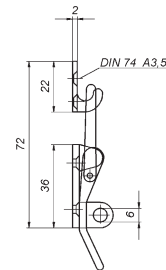

**3038 K  
mit gerader Platte  
with straight plate**

**3038 L SpannverschuB mit gerader Platte  
fastener with straight plate**

Breite / width 30 mm

102489

102487

102488

Mp

Mmch

Mpch

auf Wunsch / on request:

**mit Winkelplatte A  
with angle plate A**

107595

107596

107597

Mp

Mmch

Mpch

**mit Winkelplatte B  
with angle plate B**

107598

107599

107600

Mp

Mmch

Mpch

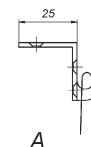

A

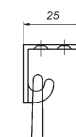

B

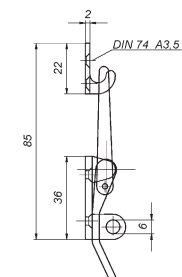

**3038 L  
mit Winkelplatte A  
with angle plate A**

## Lüftungsschieber - Garnitur ventilation slide set

bestehend aus  
consisting of

1 Stück 1367 Lüftungsschieber  
1 piece 1367 ventilation slide

+ 1 Stück 2537 Lüftungsblech  
1 piece 2537 ventilation plate

auf Wunsch  
on request

2 Stück 2537 Lüftungsbleche  
2 pieces 2537 ventilation plates

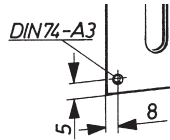

1367



2537

### 1367 Lüftungsschieber 360 x 95 mm ventilation slide

102998 Mp  
102996 Mmch  
102997 Mpch

Luftdurchlaß 70 cm<sup>2</sup>  
free air space

Einbaumaß 340 x 69 mm  
installation measurement

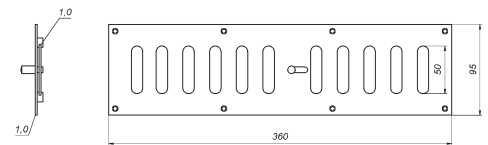

1367

### 2537 Lüftungsblech 360 x 95 mm ventilation plate

103018 Mp  
103016 Mmch  
103017 Mpch

Luftdurchlaß 70 cm<sup>2</sup>  
free air space

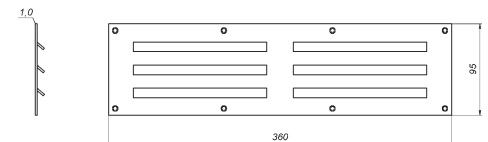

2537

### 2537 Lüftungsblech 160 x 80 mm ventilation plate

104060 Mp  
104058 Mmch  
104059 Mpch

Luftdurchlaß 35 cm<sup>2</sup>  
free air space

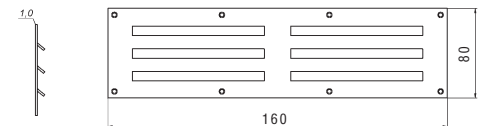

2537

### 2534 Lüftungsrosette, Knopf außen ventilation rose, knob outside

L∅ außen L∅ outside	L1∅ Lochkreis L1∅ srew-hole-circle	Luftdurchlaß free air space	Mp	Mmch	Mpch
100	190	13 cm≤	103080	103078	103079
125	115	20 cm≤	103083	103081	103082
150	140	37 cm≤	103086	103084	103085
180	170	50 cm≤	103089	103087	103088
210	200	66 cm≤	103092	103090	103091

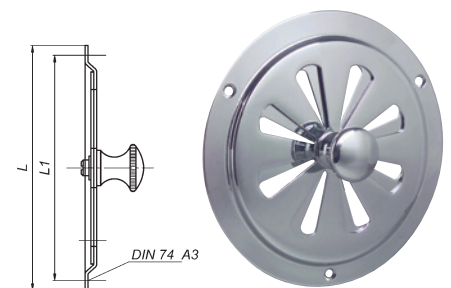

2534

### 2544 Lüftungsrosette, ohne Knopf und Drehscheibe auch als Gegenseibe zu 2534 verwendbar ventilation rose, without knob and rotation plate also usable as counterplate with 2534

L∅ außen L∅ outside	L1∅ Lochkreis L1∅ srew-hole-circle	Luftdurchlaß free air space	Mp	Mmch	Mpch
100	90	13 cm≤	103110	103108	103109
125	115	20 cm≤	103113	103111	103112
150	140	37 cm≤	103116	103114	103115
180	170	50 cm≤	103119	103117	103118
210	200	66 cm≤	103122	103120	103121

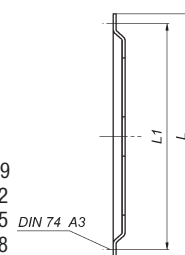

2544

**4078** Türklemme  
door spring catch  
103128  
103126  
103127

Mp  
Mmch  
Mpch

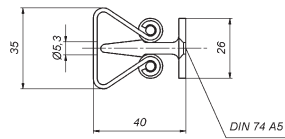

**4078**

**5078** Türklemme  
door spring catch  
103131  
103129  
103130

Mp  
Mmch  
Mpch

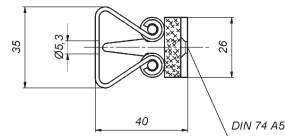

**5078**

**4078 A** Türklemme  
door spring catch  
103134  
103132  
103133

Mp  
Mmch  
Mpch

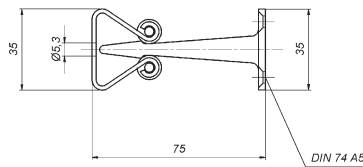

**4078 A**

**5078 A** Türklemme  
door spring catch  
103137  
103135  
103136  
auf Wunsch in 100 mm  
on request in 100 mm

Mp  
Mmch  
Mpch

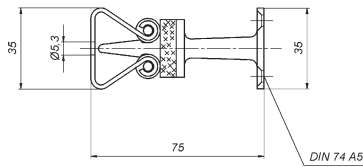

**5078 A**

**4581** Türpuffer  
door stop  
103140  
103138  
103139

Mp  
Mmch  
Mpch

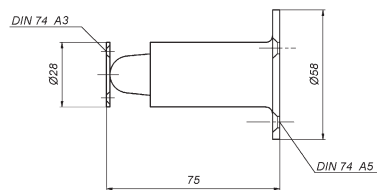

**4581**

**236** Türfallhaken  
door stop with catch  
103143  
103141  
103142

Mp  
Mmch  
Mpch

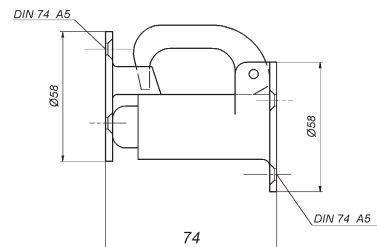

**236**  
**236 A**

**236 A** Türfallhaken  
door stop with catch  
103147  
103145  
103146

Mp  
Mmch  
Mpch

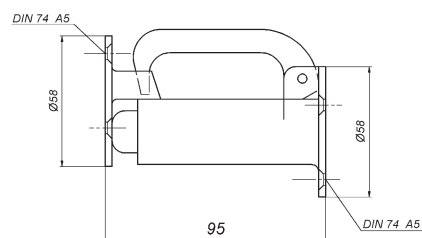

- 2406** Türfallhaken mit verstellbarer Kappe  
door stop with catch, adjustable  
103149 Mmch  
103152 Mp  
103151 Mpch

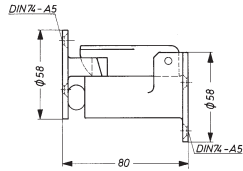

2406

- 1346** Türfallhaken mit verstellbarer Kappe  
door stop with catch, adjustable  
103164 Mmch  
103166 Mp  
103165 Mpch

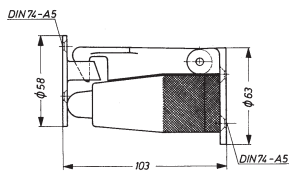

1346

- 4090** Kugelschnäpper  
ball catch
- | L  | B  | H  | L1   | DIN 74 A | Msn    | Mсни   |
|----|----|----|------|----------|--------|--------|
| 43 | 8  | 12 | 26mm | 3        | 110315 | 110388 |
| 50 | 9  | 14 | 29mm | 3        | 104202 | 110386 |
| 60 | 10 | 16 | 38mm | 3,5      | 104203 | 110389 |
| 70 | 13 | 19 | 42mm | 4        | 104204 | 110387 |

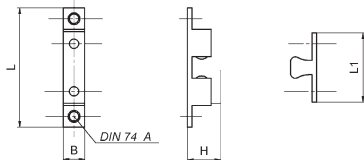

4090

- 2574** Kugelschnäpper 40 x 16 mm  
mit Schließblech  
ball catch  
with striking plate  
101945 Mp  
101943 Mmch  
101944 Mpch

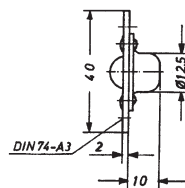

2574

- 4089** Kugelschnäpper verstellbar 60 x 18 mm  
mit Schließblech  
ball catch adjustable  
with striking plate  
101948 Mp  
101946 Mmch  
101947 Mpch

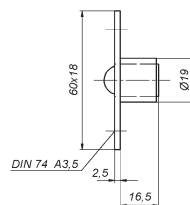

4089



**5108** **Möbelknopf**  
**cabinet knob**

D	H	d	Mp	Mmch	Mpch
Ø25	18	12 mm	101992	101990	101991
Ø35	25	16 mm	102008	102006	102007

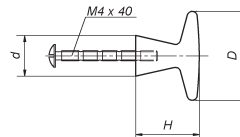

5108

**4805** **Möbelknopf**  
**cabinet knob**

D	H	d	Mp	Mmch	Mpch
Ø25	16	14 mm	102012	102010	102011
Ø38	25	18 mm	102020	102018	102019

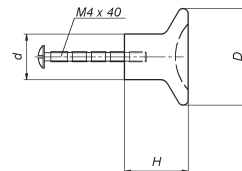

4805

**6674** **Möbelgriff**  
**cabinet pull**

	Mp	Mmch	Mpch
104133			
104131			
104132			

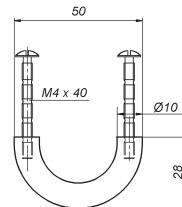

6674

**7808** **Möbelgriff 8 mm**  
**cabinet pull**

L	A		
104	096 mm	110329	Estr
136	128 mm	110330	Estr
168	160 mm	110331	Estr
200	192 mm	110332	Estr

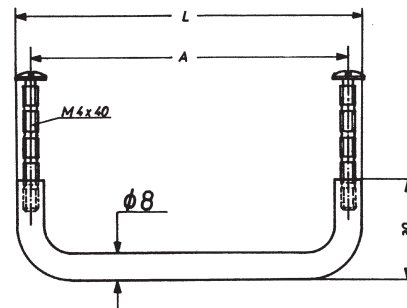

auf Wunsch:  
on request:

**7818** **Dekorplättchen 8 mm**  
**decoration plate**

	Mmv
110341	



**7810** **Möbelgriff 10 mm**  
**cabinet pull**

L	A		
106	096 mm	110335	Estr
138	128 mm	110336	Estr
170	160 mm	110337	Estr
202	192 mm	110338	Estr

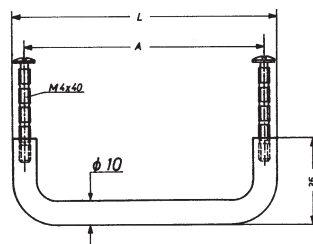

auf Wunsch:  
on request:

**7820** **Dekorplättchen 10 mm**  
**decoration plate**

	Mmv
110342	

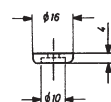

**3149 Vorreiber latch**

102667	Mp
102665	Mmch
102666	Mpch

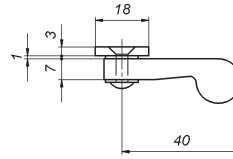

3149

**3148 Vorreiber latch**

a	Mp	Mmch	Mpch
10mm	102670	102668	102669
15mm	102673	102671	102672
20mm	102676	102674	102675
25mm	102679	102677	102678
30mm	102682	102680	102681

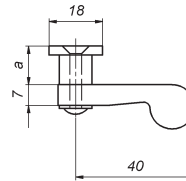

3148

**3152 Reibblech 60 x 16mm striking plate**

102685	Mp
102683	Mmch
102684	Mpch

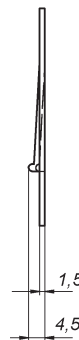

3152

**232 Vorreiber Ø 50 mm latch**

links und rechts verwendbar  
left and right usable

102688	Mp
102686	Mmch
102687	Mpch



232

**233 Vorreiber mit Arretierung Ø 50 mm latch with stop**

links left hand	rechts right hand	
101325	101328	Mp
101323	101326	Mmch
101324	101327	Mpch



233

**5651** Einlaßring 65 x 50 mm  
flush ring  
102058  
102057  
102061

Mp  
Mmch  
Mpch

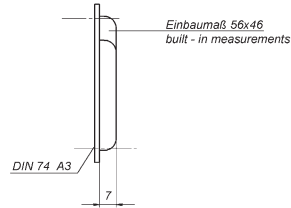

5651



**5651**

**168** Einlaßgriff 85 x 50 mm  
flush pull  
102062  
102059  
102060

Mp  
Mmch  
Mpch

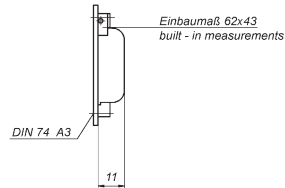

168



**168**

Muschelplatte Kst grau  
cup plastic grey

**149** Klapptischscharnier 30 x 70 mm  
folding table hinge  
104109  
104107  
104108

Mp  
Mmch  
Mpch

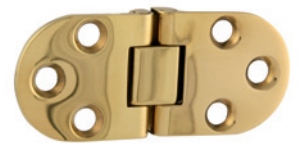
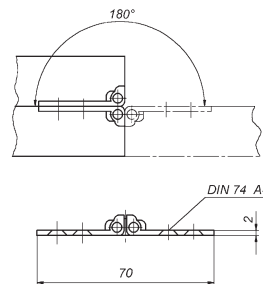

**149**

**1078** Federklemme für Schubladen-Rückseite  
spring catch for drawer backside  
101960  
101958  
101959

Mp  
Mmch  
Mpch

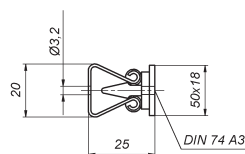

**1078**

**5432** Federklemme  
spring catch  
104072 Mp  
104070 Mmch  
104071 Mpch

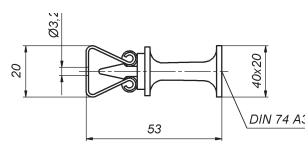

**5432**

Türklemmen Seite y-35  
door spring catches page y-35

<b>4145</b>	<b>Schrankschere gebogen</b> <b>cabinet stay curved</b>			
	Länge von Drehpunkt bis Schlitzende	links	rechts	
	length from pivot to slit end	left hand	right hand	
	100 mm	102114	102115	Mp
		102110	102111	Mmch
		102112	102113	Mpch
	Schiene/rail	12 x 2 mm		
	Anschraubwinkel / fixing angle	16 x 12 mm		
	Anschraubplatte / fixing plate	35 x 10 mm		
	Senkung / countersinking	DIN 74 A3		

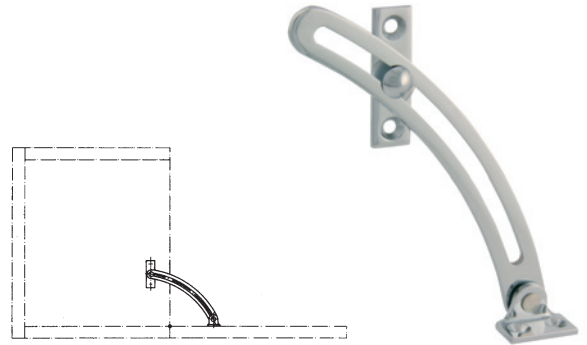

4145

<b>2658</b>	<b>Schrankschere mit Arretierung</b> <b>cabinet stay with stop</b>			
	Länge aufgeklappt	links	rechts	
	length overall	left hand	right hand	
	250 mm	102077	102078	Mp
		102074	102075	Mmch
		102076	102079	Mpch
	300 mm	102084	102085	Mp
		102080	102081	Mmch
		102083	102082	Mpch
	Schiene/rail	12 x 2 mm		
	Anschraubwinkel/ fixing angle	26 x 12 mm		
	Anschraubplatte / fixing plate	34 x 13 mm		
	Senkung / countersinking	DIN 74 A3		

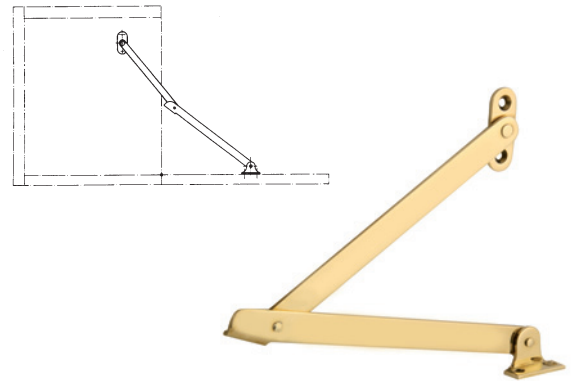

2658

<b>4825</b>	<b>Schrankschere mit Einrastung</b> <b>cabinet stay with built-in catch</b>			
	Schlitzlänge	links	rechts	
	length of slit	left hand	right hand	
	105 mm	102096	102097	Mp
		102092	102093	Mmch
		102094	102095	Mpch
	Schiene/rail	15 / 18 x 2,5 mm		
	Anschraubwinkel / fixing angle	40 x 22mm		
	Senkung / countersinking	DIN 74 A4		

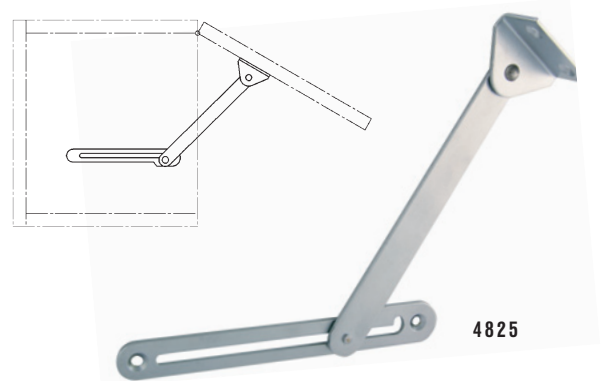

4825

<b>2654</b>	<b>Schrankschere mit Feststellmutter</b> <b>Feder und Plastik-Scheiben</b> <b>cabinet stay with set-screw</b> <b>spring and plastic washer</b>			
	Länge von Drehpunkt bis Schlitzende			
	length from pivot to slit end			
	195 mm	102106		Mp
		102104		Mmch
		102105		Mpch
	220 mm	106098		Mp
		106096		Mmch
		106097		Mpch
	300 mm	102109		Mp
		102107		Mmch
		102108		Mpch
	Schiene/rail	20 x 3 mm		
	Anschraubwinkel/ fixing angle	40 x 22 mm		
	Anschraubplatte / fixing plate	50 x 22 mm		
	Senkung / countersinking	DIN 74 A4		

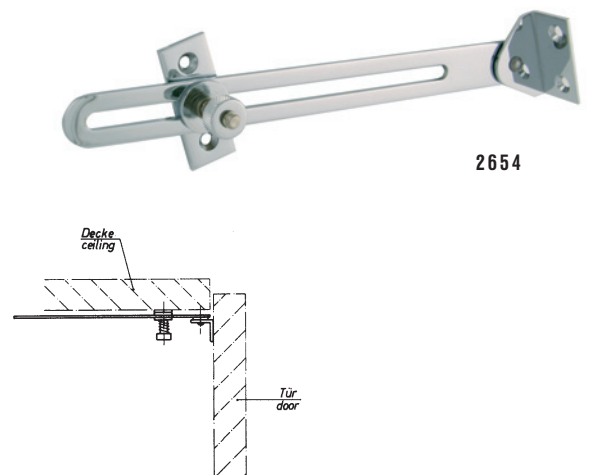

2654

3361	<b>Möbelriegel 8 x 2,5 mm, gerade</b> cabinet bolts 8 x 2.5 mm, straight					
	Länge	Breite	DIN 74 A	Mp	Mmch	Mpch
	length	width				
	40mm	25mm	3	102509	102507	102508
	50mm	25mm	3	107052	106095	107053
60mm	25mm	3	102514	102512	102513	
80mm	25mm	3	102517	102515	102516	



3361

3461	<b>Schlaufe</b> surface striking plate			Mp	Mmch	Mpch
				102523	102521	102522



3461

3361 A	<b>Möbelriegel 8 x 3 mm, gekröpft</b> cabinet bolts 8 x 3 mm, offset					
	Länge	Breite	DIN 74 A	Mp	Mmch	Mpch
	length	width				
	40mm	25mm	3	102526	102524	102525
	50mm	25mm	3	107841	107842	107843
60mm	25mm	3	102529	102527	102528	
80mm	25mm	3	102533	102530	102531	



3361 A

3461 A	<b>Schlaufe</b> surface striking plate			Mp	Mmch	Mpch
				102538	102536	102537



3461 A

Bitte beachten Sie bei GSV 3361/3361A entsprechende Mindestbestellmengen!  
Please note minimum order quantities for GSV 3361/3361A!

2512	<b>Bolzenriegel mit Schließmuffe</b> barrei bolt with surface striking plate						
	Länge	Breite	Bolzen	DIN 74 A	Mp	Mmch	Mpch
	length	width	barrel	Ø			
	50mm	28mm	8	3	101331	101329	101330
	75mm	35mm	8	3,5	101340	101338	101339
100mm	45mm	10	4,5	101337	101335	101336	
125mm	45mm	10	4,5	101334	101332	101333	

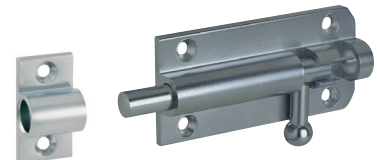

2512

2512 A	<b>Bolzenriegel mit Schließblech</b> barrei bolt with surface striking plate						
	Länge	Breite	Bolzen	DIN 74 A	Mp	Mmch	Mpch
	length	width	barrel	Ø			
	50mm	28mm	8	3	102629	102627	102628
	75mm	35mm	8	3,5	102632	102630	102631
100mm	45mm	10	4,5	102635	102633	102634	
125mm	45mm	10	4,5	102638	102636	102637	

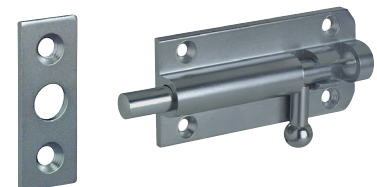

2512 A

2512 B	<b>Bolzenriegel mit Schließwinkel</b> barrei bolt with angle striking plate						
	Länge	Breite	Bolzen	DIN 74 A	Mp	Mmch	Mpch
	length	width	barrel	Ø			
	50mm	28mm	8	3	102640	102639	102641
	75mm	35mm	8	3,5	102644	102642	102643
100mm	45mm	10	4,5	102647	102645	102646	
125mm	45mm	10	4,5	102650	102648	102649	

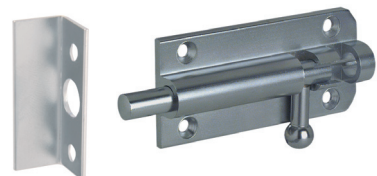

2512 B

4730

**Schlengerleistenhalter**  
**anti-rolling ledge holder**

b	b1	h	t	DIN A	Mp	Mmch	Mpch
8	12	25	12	3	102761	102760	102759
12	16	30	14	3	110875	108195	110874
16	20	45	20	4	107464	107465	107466

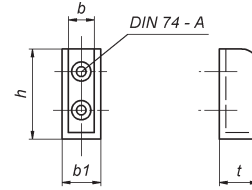

4730

238

**Geschirrhaken**  
**cup hook**

∅	w	h	t	d	Mp	Mmch	Mpch
20	9	21	15	4	103707	103704	103706
25	12	26	18	5	103710	103708	103709
30	15	30	20	6	103714	103712	103713
35	18	34	20	6	103718	103716	103717

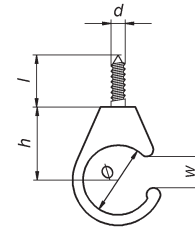

238

2494 G

**Handtuchhaken**  
**towel hook**

103463	Mp
103461	Mmch
103462	Mpch

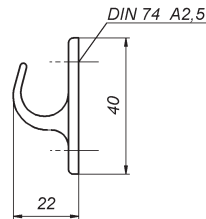

2494 G

4348 A

**Kleiderhaken**  
**coat hook**

104066	Mp
104064	Mmch
104065	Mpch

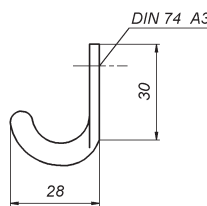

4348 A

4348

**Huthaken**  
**hat hook**

104063	Mp
104061	Mmch
104062	Mpch

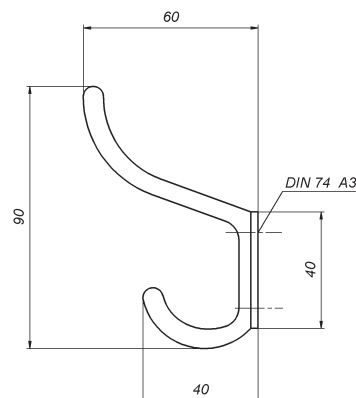

4348

164

**Türhaken mit Öse**  
**cabin hook with eye**  
 Anschraubplatte 35 x 22 mm  
 fixing plate 35 x 22 mm

L	Mp	Mmch	Mpch
60 mm	103342	103340	103341
80 mm	103345	103343	103344
100 mm	103348	103346	103347
125 mm	103351	103349	103350



164

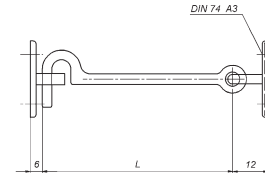

229 G

**Türhaken mit Öse**  
**cabin hook with eye**

L	Anschraubplatte fixing plate	Öse Ø eye Ø	Mp	Mmch	Mpch
50 mm	40 x 22 mm	6 mm	103363	103361	103362
75 mm	40 x 22 mm	6 mm	103366	103364	103365
100 mm	40 x 22 mm	6 mm	103369	103367	103368
125 mm	45 x 25 mm	8 mm	103372	103370	103371
150 mm	45 x 25 mm	8 mm	103375	103373	103374
175 mm	45 x 25 mm	8 mm	103378	103376	103377
200 mm	45 x 25 mm	8 mm	103381	103379	103380



229 G

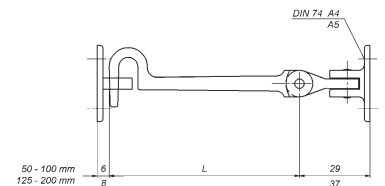

2507 G

**Öse für Türhaken**  
**eye for door hook**

	Mp	Mmch	Mpch
40 x 22 mm für / for 229 G / 50 - 100	107831	106502	107832
45 x 25 mm für / for 229 G / 125 - 200	110789	110787	110788



2507 G

auf Wunsch 2. Öse:  
 on request 2nd eye:

Handlauf-/ Fußleistenprodukte auf Anfrage  
Handrail-/ Skirting system products on request



2809



2809

Beispiele für die Kombination von Schwepper-Schlössern mit Designer-Produkten  
Examples for the combination of Schwepper-locks and designer-products



2709



Schloss- und Beschlagprodukte in Sonderausführungen  
Lock- and hardware products to customer's specification

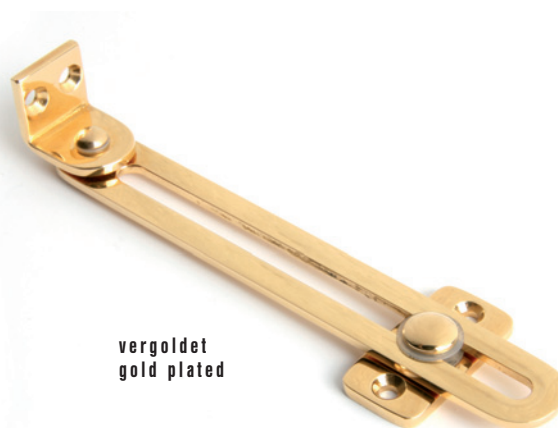

vergoldet  
gold plated